

General Specifications

YTA110 Temperature Transmitter



GS 01C50B01-00EN

The YTA110 is the high performance temperature transmitter that accepts Thermocouple, RTD, ohms or DC millivolts inputs and converts it to a 4 to 20 mA DC signal for transmission. The YTA110 supports either BRAIN or HART communication protocol.

The YTA110 in its standard configuration is certified by TÜV as complying with SIL2 for safety requirement.

■ FEATURES

High performance

Microprocessor-based sensing technology ensures long-term accuracy and high reliability.

High reliability

Dual-compartment housing realizes high resistance capability to harsh environments, and YTA110 has SIL2 capability for safety requirement.

Variety of sensor inputs

The type of sensor input is user-selectable from thermocouples (T/C), RTDs, ohms, or DC millivolts.

Digital communication

BRAIN or HART® communication protocol is available. The instrument configuration can be changed by the user with using the BT200 or HART communicator.

Self-diagnostics function

Continuous self-diagnostics capability ensures longterm performance and lower cost of ownership.

LCD display with bargraph

The LCD display provides both a digital readout and percent bargraph simultaneously.

■ STANDARD SPECIFICATIONS

■ PERFORMANCE SPECIFICATIONS

Accuracy

(A/D accuracy/span + D/A accuracy) or $\pm 0.1\%$ of calibrated span, whichever is greater.
See Table 1. on page 3.

Cold Junction Compensation Accuracy

(For T/C only)
 $\pm 0.5^\circ\text{C}$ ($\pm 0.9^\circ\text{F}$)

Ambient Temperature Effect (per 10°C change)

$\pm 0.1\%$ or \pm (Temperature Coefficient /span), whichever is greater. See Table 2. for Temperature Coefficient.



Stability

RTD:

$\pm 0.1\%$ of reading or $\pm 0.1^\circ\text{C}$ per 2 years, whichever is greater at $23\pm 2^\circ\text{C}$.

T/C:

$\pm 0.1\%$ of reading or $\pm 0.1^\circ\text{C}$ per year, whichever is greater at $23\pm 2^\circ\text{C}$.

5 Year Stability

RTD:

$\pm 0.2\%$ of reading or $\pm 0.2^\circ\text{C}$, whichever is greater at $23\pm 2^\circ\text{C}$.

T/sC:

$\pm 0.4\%$ of reading or $\pm 0.4^\circ\text{C}$, whichever is greater at $23\pm 2^\circ\text{C}$.

Power Supply Effect

$\pm 0.005\%$ of calibration span per volt

Vibration Effect

10 to 60 Hz 0.21 mm peak displacement
60 to 2000 Hz 3G

Position Effect

None

■ FUNCTIONAL SPECIFICATIONS

Input

Input type is selectable: Thermocouples, 2-, 3-, and 4-wire RTDs, ohms and DC millivolts. See Table 1. on page 3.

Span & Range Limits

See Table 1. on page 3.

Input signal source resistance (for T/C, mV)

1 k Ω or lower

Input lead wire resistance (for RTD, ohm)

10 Ω per wire or lower

Output

Two wire 4 to 20 mA DC. Output range: 3.68 mA to 20.8 mA

BRAIN or HART® protocol is superimposed on the 4 to 20 mA signal.

Any single value from the followings can be selected as the analog output signal.

Sensor 1, Terminal Temperature.

Also, up to three of the above values can be displayed on LCD display or read via communication.

Isolation

Input/Output/GND isolated to 500 V DC

Sensor Burnout

High (21.6 mA DC) or Low (3.6 mA DC), userselectable.

Output in Transmitter Failure

Up-scale: 110%, 21.6 mA DC or more (Standard or Optional code /C3)

Down-scale: -5%, 3.2 mA DC or less (Optional code /C1 or /C2)

Update Time

Approximately 0.5 seconds

Turn-on Time

Approximately 5 seconds

Damping Time Constant

Selectable from 0 to 99 seconds

Ambient Temperature Limits

Option code may affect limits.

-40 to 85°C (-40 to 185°F)

-30 to 80°C (-22 to 176°F) with Integral Indicator

Ambient Humidity Limits

5 to 100% RH at 40°C (104°F)

EMC Conformity Standards

EN61326-1 Class A, Table2

EN61326-2-3

CE Marking is not conformed.

SIL Certification

YTA110 temperature transmitter is certified by TÜV NORD CERT GmbH in compliance with the following standards;

IEC 61508: 2000; Part1 to Part 7 Functional Safety of Electrical/electronic/programmable electronic related systems;

SIL 2 capability for single transmitter use, SIL 3 capability for dual transmitter use.

Self-calibration

The analog-to-digital measurement circuitry automatically self-calibrates for temperature update by comparing the dynamic measurement to extremely stable and accurate internal reference elements.

Self-diagnostics

Loss of input error, ambient temperature error, EEPROM error, and CPU error. Up to four error history can be stored in the memory.

Manual Output Function

The output value can be set manually.

Supply & Load Requirements

Supply Voltage

10.5 to 42 V DC for general use and flameproof type
10.5 to 32 CV DC for lightning protector (Optional code /A)

10.5 to 30 V DC for intrinsically safe, Type n, nonincendive, or non-sparking type

Minimum voltage limited at 16.4 V DC for digital communications, BRAIN and HART® protocols

Load

0 to 1335 Ω for operation

250 to 600 Ω for digital communication

See Figure 1. on page 4.

Communication Requirements

BRAIN:

Communication Distance

Up to 2 km (1.25 miles) when using CEV polyethylene-insulated PVC-sheathed cables.

Communication distance varies depending on type of cable used.

Load Capacitance

0.22 μF or less

Load Inductance

3.3 mH or less

Input Impedance of communicating device

10 kΩ or more at 2.4 kHz.

■ PHYSICAL SPECIFICATIONS

Enclosure

Material

Low copper cast-aluminum alloy or SCS14A stainless steel (option, equivalent to SUS316 cast stainless steel and ASTM CF-8M)

Coating

Polyurethan resin baked finish

Color: Deep-sea moss green (Munsell 0.6GY3.1/2.0)

Degrees of Protection

IP66/IP67, NEMA4X

Data and tag plate

SUS304 stainless steel or SUS316 stainless steel (option)

Mounting

Optional mounting brackets can be used either for two-inch pipe or flat panel mounting.

Terminal Screws

M4 screws

Integral Indicator

Optional LCD digital indicator includes 5-digit numerical display with °C, K, °F, °R, % and mV, 0 to 100 % bargraph and dot-matrix display.

Weight

1.2 kg(2.6 lb) without Integral indicator and Mounting bracket. Integral indicator weights 0.2 kg(0.4 lb).

Bracket for horizontal pipe: 0.3 kg

Bracket for vertical pipe: 1.0 kg

Electrical Connections

Refer to 'MODEL AND SUFFIX CODES' on page 5.

Table 1. Sensor type, measurement range, and accuracy

Sensor Type	Reference Standard	Measurement Range		Minimum Span (Recommended)	Accuracy							
					Input range		A/D Accuracy		D/A Accuracy			
		°C	°F		°C	°F	°C	°F				
Y/C	B	IEC584	100 to 1820	212 to 3308	25°C (45°F)	100 to 300	212 to 572	±3.0	±5.4	±0.02% of span		
	E		-200 to 1000	-328 to 1832		300 to 400	572 to 752	±1.0	±1.8			
	J		-200 to 1200	-328 to 2192		400 to 1820	752 to 3308	±0.75	±1.35			
	K		-200 to 1372	-328 to 2502		-200 to -50	-328 to -58	±0.35	±0.63			
	N		-200 to 1300	-328 to 2372		-50 to 1000	-58 to 1832	±0.16	±0.29			
	R		-50 to 1768	-58 to 3214		-200 to -50	-328 to -58	±0.40	±0.72			
	S		-50 to 1768	-58 to 3214		-50 to 1200	-58 to 2192	±0.20	±0.36			
	T		-200 to 400	-328 to 752		-200 to -50	-328 to -58	±0.50	±0.90			
	W3		ASTM E988	0 to 2300		32 to 4172	-50 to 1372	-58 to 2502	±0.25		±0.45	
	W5			0 to 2300		32 to 4172	-200 to -50	-328 to -58	±0.80		±1.44	
	L			DIN43710		-200 to 900	-328 to 1652	-50 to 1300	-58 to 2372		±0.35	±0.63
						-200 to 600	-328 to 1112	-50 to 0	-58 to 32		±1.0	±1.8
U	-200 to 900	-328 to 1652	0 to 100	32 to 212	±0.80	±1.44						
RTD	Pt100	IEC751	-200 to 850	-328 to 1562	100 to 600	212 to 1112	±0.60	±1.08				
	Pt200		-200 to 850	-328 to 1562	600 to 1768	1112 to 3214	±0.40	±0.72				
	Pt500		-200 to 850	-328 to 1562	-200 to -50	-328 to -58	±0.25	±0.45				
	JPt100		-200 to 500	-328 to 932	-50 to 400	-58 to 752	±0.14	±0.25				
	Cu	SAMA RC21-4	-70 to 150	-94 to 302	0 to 400	32 to 752	±0.80	±1.44				
			-70 to 150	-94 to 302	400 to 1400	752 to 2552	±0.50	±0.90				
			-70 to 150	-94 to 302	1400 to 2000	2552 to 3632	±0.60	±1.08				
			-70 to 150	-94 to 302	2000 to 2300	3632 to 4172	±0.90	±1.62				
mV	—	-10 to 100 [mV]		3 [mV]	—		±12 [μV]					
ohm	—	0 to 2000 [Ω]		20 [Ω]	—		±0.35 [Ω]					

Total Accuracy = (A/D Accuracy / Span + D/A Accuracy) or (± 0.1% of calibrated span), whichever is greater.

For T/C input, add Cold Junction Compensation Accuracy (± 0.5 °C) to the total accuracy.

Example; when selecting Pt100 with measurement range of 0 to 200 °C.

$$\frac{0.14^{\circ}\text{C}}{200^{\circ}\text{C}} \times 100\% \text{ of span} + 0.02\% \text{ of span} = 0.09\% \text{ of span}$$

Since the value is smaller than ± 0.1% of span, the total accuracy is ± 0.1%.

Table 2. Temperature Coefficient

Sensor Type		Temperature Coefficient
Thermocouples E, J, K, N, T, L, U		0.08°C + 0.02% of abs.reading
Thermocouples R, S, W3, W5		0.25°C + 0.02% of abs.reading
T/C B	100°C ≤ Reading < 300°C	1°C + 0.02% of abs.reading
	300°C ≤ Reading	0.5°C + 0.02% of abs.reading
RTD		0.08°C + 0.02% of abs.reading
mV		0.002 mV + 0.02% of abs.reading
ohm		0.1 Ω + 0.02% of abs.reading

Note 1: Ambient Temperature Effect per 10°C change is ±0.1% or ±(temperature coefficient/span), whichever is greater.

Note 2: The "abs.reading" on Table2 means the absolute value of the reading in °C.

Example of abs reading;

When the temperature value is 250 Kelvin, abs reading is 23.15, absolute (250-273.15).

Example of Ambient Temperature Effect;

Conditions;

- 1) Input Sensor: Pt100
- 2) Calibration Range: -100 to 100°C
- 3) Reading value: -50°C

Ambient Temperature Effect per 10°C;

$$\text{Temperature Coefficient/Span} = (0.08^\circ\text{C} + 0.02/100 \times |-50^\circ\text{C}|) / \{100^\circ\text{C} - (-100^\circ\text{C})\} = 0.00045 \rightarrow 0.045\%$$

Therefore, Ambient Temperature Effect is ±0.1%/10°C

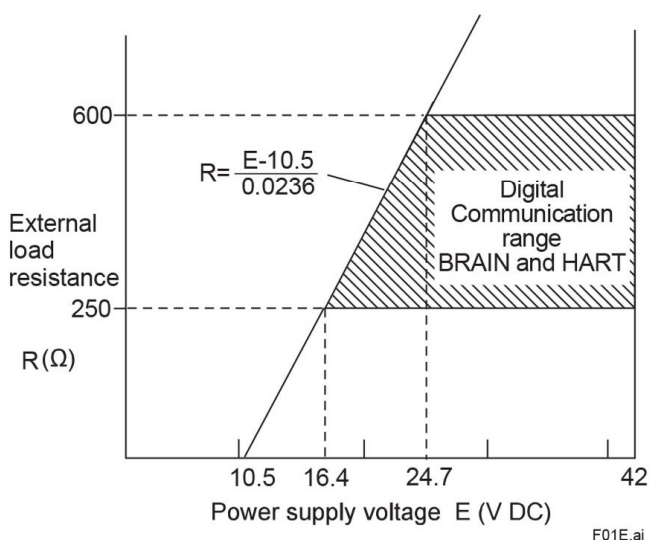

Figure 1. Relationship Between Power Supply Voltage and External Load Resistance.

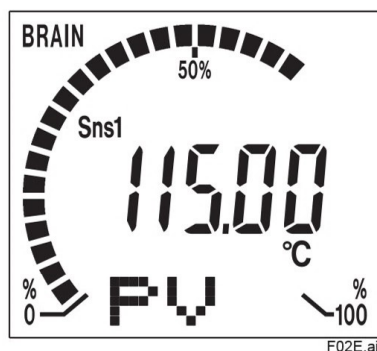

Figure 2. Integral Indicator Display Example.

MODEL AND SUFFIX CODES

Model	Suffix Codes	Descriptions
YTA110	Temperature Transmitter
Output Signal	-D..... -E.....	4 to 20 mA DC with digital communication (BRAIN protocol) 4 to 20 mA DC with digital communication (HART protocol, refer to GS 01C50T01-00EN)
—	A	Always A
Electrical Connection	0 2 3 4	G1/2 female 1/2 NPT female Pg 13.5 female M20 female
Integral Indicator	D N	with digital indicator None
Mounting Bracket	B D J K N	SUS304 Stainless steel 2-inch horizontal pipe mounting *1 SUS304 Stainless steel 2-inch vertical pipe mounting *1 SUS316 Stainless steel 2-inch horizontal pipe mounting *1 SUS316 Stainless steel 2-inch vertical pipe mounting *1 None
Option codes	/□ Optional specifications	

*1: For flat-panel mounting, please prepare bolts and nuts.

OPTIONAL SPECIFICATION

Item	Description	Code		
Lightning protector	Power supply voltage: 10.5 to 32 V DC Allowable current: Max. 6000 A (1×40μs), repeating 1000 A (1×40μs) 100 times	A		
Painting	Coating change	Epoxy resin coating	X1	
	Color change	Amplifier cover only	Munsell code: N1.5 Black	P1
			Munsell code: 7.5BG4/1.5, Jade green	P2
			Metallic silver	P7
	Amplifier and terminal Covers	Munsell code: 7.5 R4/14 Red	PR	
SUS316 exterior parts	Exterior parts on the amplifier housing (name plates, tag plate, screws) will become SUS316 stainless steel *2	HC		
Calibration Unit	Degree F/Degree R unit	D2		
Output signal low-side in Transmitter failure	Output signal low-side: -5%, 3.2 mA DC or less. Sensor burnout is also set to 'LOW': -2.5%, 3.6 mA DC.	C1		
NAMUR NE43 Compliant	Output signal limits: 3.8 mA to 20.5 mA	Failure alarm down-scale: output status at CPU failure and hardware error is -5%, 3.2 mA or less. Sensor burnout is also set to LOW: -2.5%, 3.6 mA DC.	C2	
		Failure alarm up-scale: output status at CPU failure and hardware error is 110%, 21.6 mA or more. In this case Sensor burnout is High: 110%, 21.6 mA DC.	C3	
Data Configuration	Description into "Descriptor" parameter of HART protocol (max. 16 characters)	CA		
Stainless steel housing *1	Housing Material: SCS14A stainless steel (equivalent to SUS316 cast stainless steel and ASTM CF-8M)	E1		
Wired tag plate	SUS304 stainless steel tag plate wired onto transmitter *3	N4		

*1: Not applicable for optional code JF3, G12, P1, P2, P7, PR, and X1.

*2: This specification is not included in option code E1. Select HC for SUS316 exterior parts regardless of E1.

*3: When HC is selected, the material is SUS316 stainless steel.

OPTIONAL SPECIFICATION (For Explosion Protected type)

Item	Description	Code
Canadian Standards Association (CSA)	<p>CSA Intrinsically safe, non-incendive and Explosionproof approval combination</p> <p>[Intrinsically safe/non-incendive approval] Applicable standard: C22.2 No0, C22.2 No0.4, C22.2 No25, C22.2 No94, C22.2 No142, C22.2 No157, C22.2 No213 Certificate: 172608-0001053837 Intrinsically safe for Class I, Division 1, Groups A, B, C and D; Class II, Division 1, Groups E, F and G; Class III, Division 1: Non-incendive for Class I, Division 2, Groups A, B, C and D; Class II, Division 2, Groups E, F and G; Class III, Division 1: Enclosure Type 4X Temperature Class: T4, Ambient Temperature: -40 to 60°C Supply: Vmax=30 V, Imax=165 mA, Pmax=0.9W, Ci=18nF, Li=730µH Sensor input: Voc=9 V, Isc=40 mA, Po=0.09W, Ca=1µF, La=10 mH Electrical Connection: 1/2 NPT female*2</p> <p>[Explosionproof approval] Applicable standard: C22.2 No0, C22.2 No0.4, C22.2 No25, C22.2 No30, C22.2 No94, C22.2 No142, C22.2 No157, C22.2 No213, C22.2 No1010.1 Certificate: 1089576 Explosionproof Class I, Div.1, Groups B, C and D, Class II, Groups E, F and G, Class III. For Class I, Div.2 Locations "FACTORY SEALED, CONDUIT SEAL NOT REQUIRED" Enclosure TYPE 4X Temperature Class: T6 Ambient Temperature: -40 to 60°C Electrical Connection: 1/2 NPT female*2</p>	CU1
Factory Mutual (FM)	<p>FM Intrinsically safe, non-incendive and Explosionproof approval combination</p> <p>[Intrinsically safe/non-incendive approval] Applicable standard: FM 3600, FM 3610, FM 3611, FM 3810 Intrinsically safe for Class I, II, III Division 1 Groups A, B, C, D, E, F and G. Non-incendive for Class I, II, Division 2 Groups A, B, C, D, F and G Class III, Division 1. Enclosure Type: 4X Temperature Class: T4 Ambient Temperature: -40 to 60°C (-40 to 140°F) Supply: Vmax=30 V, Imax=165 mA, Pmax=0.9W, Ci=18nF, Li=730µH Sensor: Voc=9 V, Isc=40 mA, Po=0.09W, Ca=1µF, La=10 mH</p> <p>[Explosionproof approval] Applicable standard: FM 3600, FM 3615, FM 3810, ANSI/NEMA 250 Class I, Division 1, Groups A, B, C and D.; Dust-ignitionproof for Class II/III, Division 1, Groups E, F and G. "FACTORY SEALD, CONDUIT SEAL NOT REQUIRED." Enclosure Ratings: TYPE 4X Temperature Class: T6 Ambient Temperature: -40 to 60°C (-40 to 140°F) Electrical Connection: 1/2NPT female*2</p>	FU1
	<p>FM Explosionproof approval Applicable standard: FM 3600, FM 3615, FM 3810, ANSI/NEMA 250 Explosionproof Class I, Division 1, Groups A, B, C and D; Dust-ignitionproof for Class II/III, Division 1, Groups E, F and G. "FACTORY SEALED, CONDUIT SEAL NOT REQUIRED." Enclosure Rating: TYPE 4X Temperature Class: T6 Ambient Temperature: -40 to 60°C (-40 to 140°F) Electrical Connection: 1/2 NPT female*2</p>	FF1
IECEX	<p>IECEX Intrinsically safe, Flameproof and Dust ignition proof Approval</p> <p>[Intrinsically safe approval] Applicable standard: IEC 60079-11:2011, IEC 60079-0:2011, IEC 60079-26:2006 Certificate No.: IECEX KEM 09.0032X Ex ia IIC T4...T5 Ga, Ex ic IIC T4...T5 Gc Ambient Temperature: -40 to 70°C for T4, -40 to 50°C for T5 Enclosure: IP66/IP67 Supply circuit : Ui = 30 V, li = 165 mA, Pi = 900 mW, Ci = 20nF, Li = 730µH (Ex ia IIC T4...T5 Ga) : Ui = 30 V, Ci = 20nF, Li = 730µH (Ex ic IIC T4...T5 Gc) Sensor circuit: Uo = 9 V, lo = 40 mA, Po = 90 mW, Co = 0.7µF, Lo = 10 mH</p> <p>[Flameproof and Dust ignition proof] Applicable Standard: IEC 60079-0: 2011, IEC 60079-1: 2014-06, IEC 60079-31:2013 Certificate: IECEX KEM 07.0044 Ex db IIC T6/T5 Gb, Ex tb IIIC T70°C/T90°C Db Ambient Temperature for Gas Atmospheres: -40 to 75°C (-40 to 167°F) for T6, -40 to 80°C (-40 to 176°F) for T5 Ambient Temperature for Dust Atmospheres: -30 to 65°C (-22 to 149°F) for T70°C, -30 to 80°C (-22 to 176°F) for T90°C Enclosure: IP66/IP67 Electrical Connection: 1/2 NPT female and M20 female*1</p>	SU2

Item	Description	Code
TIIS Certification*3	TIIS Flameproof approval Ex ds IIC T6 X Amb. Temp.: -20 to 60°C	JF3
Attached flameproof packing adapter*4	Electrical connection: G1/2 female Applicable cable: O.D. 8.5 to 11 mm	2 pc. G12

*1: Applicable for Electrical Connection Code 2 and 4.

*2: Applicable for Electrical Connection Code 2.

*3: Not applicable for /HC and /E1.

*4: If cable wiring is to be used to a TIIS flameproof type transmitter, do not fail to add the YOKOGAWA-assured flameproof packing adapter.

DIMENSIONS

Unit: mm (Approx. inch)

● 2-inch horizontal pipe mounting

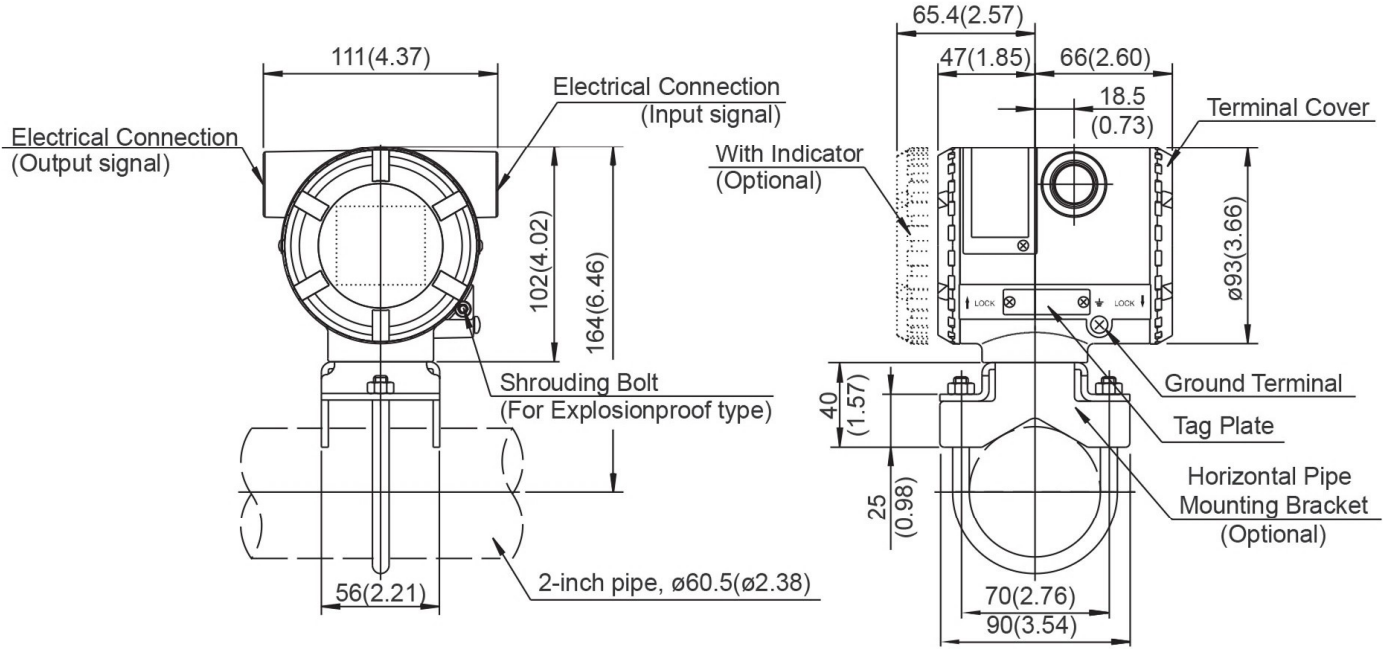

● 2-inch vertical pipe or horizontal mounting

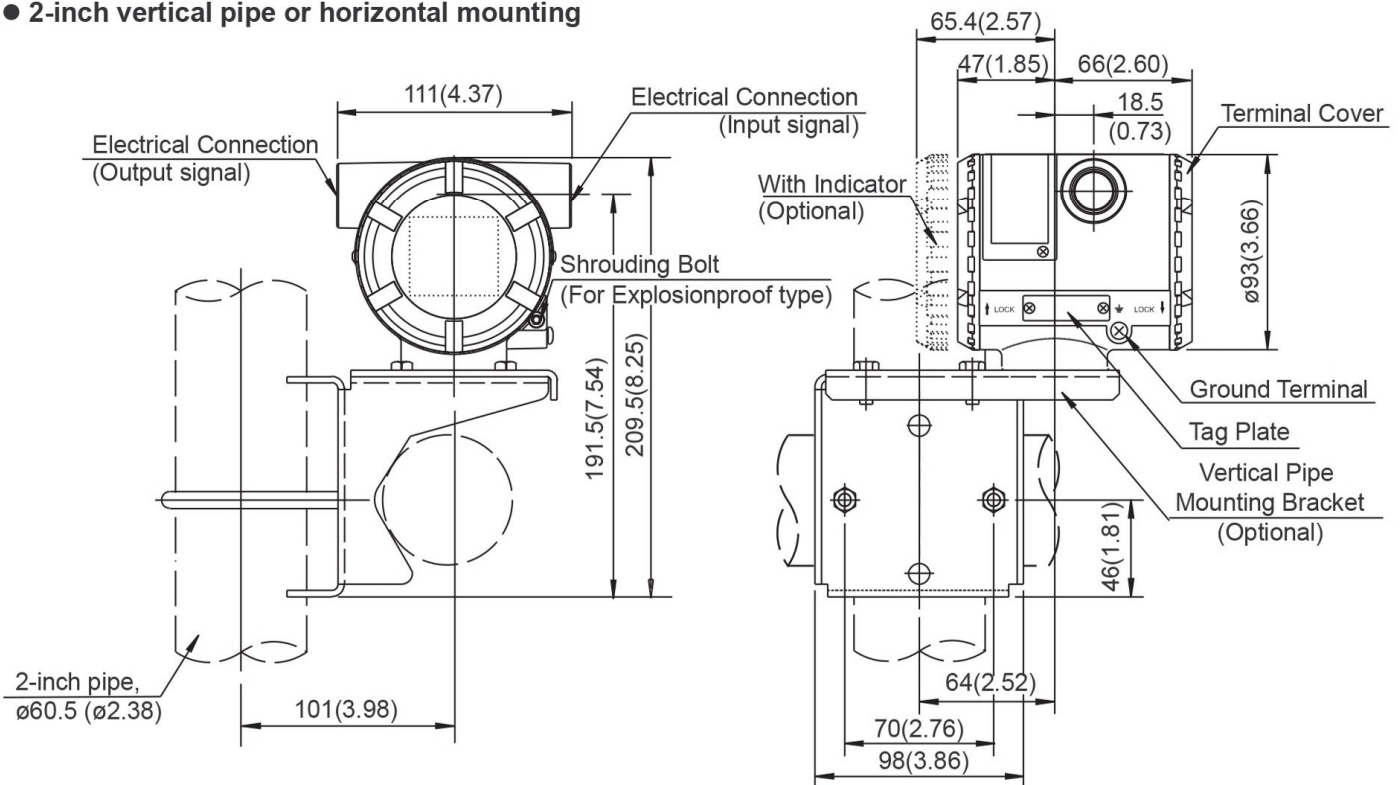

F03E.ai

Terminals

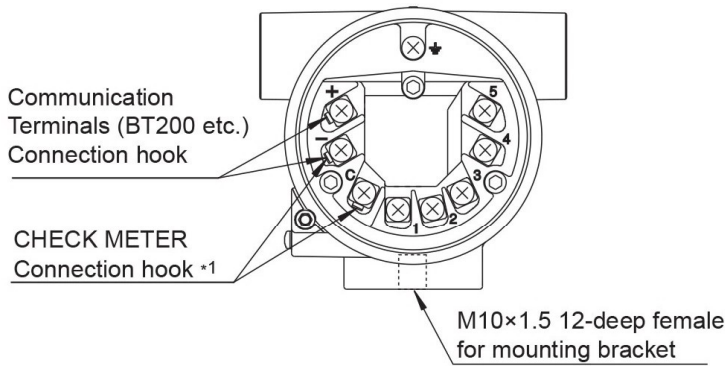

Terminal Configuration

+	Power Supply and output terminal
-	External Indicator (ammeter) terminal *1
⏏	Ground terminal

*1: When using an external indicator or check meter, the internal resistance must be 10Ω or less. This hook is not available for Fieldbus communication type(output signal code F).

F04E.ai

Input Wiring

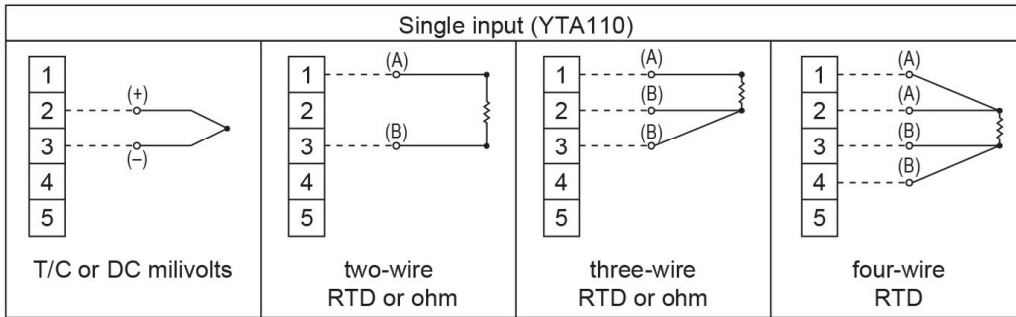

F05E.ai

< Ordering Information >

Specify the following when ordering Model, suffix codes, and optional codes.

The instrument is shipped with the settings shown in Table A. Specify the following when necessary.

1. Sensor type.
For RTD and resistance input, specify the number of wire as well. (Example; Pt200 3-wire system)
2. Calibration range and unit
 - 1) Calibration range can be specified within the measurement range shown in Table 1. on page 3.
 - 2) Specify one range from °C, K, °F or °R for temperature input. °F and °R are available when Optional code D2 is specified. It is not necessary to specify the unit of mV and ohm inputs, for these units automatically will be mV or Ω.
3. Tag Number
4. Other Items related with options
/CA option allows specifying the setting Descriptor for HART protocol type at factory. Specify upto 16 characters to be entered in the Descriptor parameter.

Table A. Settings upon shipment

Input sensor type	Pt100 three-wire system, or as specified
Calibration range lower limit	"0" or as specified
Calibration range upper limit	"100" or as specified
Calibration unit	"°C" or as specified
Damping time constant	2 seconds
Sensor burnout *1	High (110%, 21.6 mA DC)
Output in Transmitter failure *1	High (110%, 21.6 mA DC or more)
Integral Indicator *2	PV
Output type	Sensor 1
Tag number	As specified in order

*1: Except when Optional code C1 or C2 is specified.
*2: When Integral indicator is specified.

< Related Instruments >

Power Distributor:
Refer to GS 01B04T01-02E or GS 01B04T02-00E
BRAIN TERMINAL: Refer to GS 01C00A11-00E

< Reference >

HART; Trademark of The HART Communication Foundation. (USA)

Material Cross Reference Table

SUS304	AISI 304
SUS316	AISI 316