



Level



Pressure



Flow



Temperature



Liquid  
Analysis



Registration



Systems  
Components



Services



Solutions

## Technical Information

# Deltapilot S DB50/50L/51/52/53

## Hydrostatic Level Measurement

Pressure sensor with CONTITE™ measuring cell;  
waterproof, climatic-proofed, long-term stability; for food, fresh  
water and wastewater, chemical and pharmaceutical products



### Application

The devices in the Deltapilot S product family are used for continuous level measurement in all liquid and paste-like media. They are used in both the chemical, pharmaceutical and food industry as well as in the water and wastewater sector.

Switching units perfectly in line with the application:

- Determine the level, volume, differential pressure, density and product weight
- Control limit contacts
- Integrate the measuring point in various automation systems.

### Your benefits

- Hermetically sealed CONTITE™ measuring cell:
  - Climatic-proofed and with high long-term stability
  - Maximum linearity (better than 0.1 % of the set measuring range)
  - Minimum temperature effects (better than 0.1%/10 K).
- Compact, rod or cable versions available
- Separate mounting of housing and electronic insert (IP 68 protection at the measuring point)
- Easy and comfortable operation:
  - Onsite with display and operating module
  - Operation via communication
- Replaceable electronic inserts:
  - 4 to 20 mA HART
  - PROFIBUS PA
  - FOUNDATION Fieldbus
  - Analog output
  - PFM

## Table of contents

<b>Function and system design</b> .....	<b>4</b>	<b>Operating conditions (environment)</b> .....	<b>20</b>
Device selection .....	4	Ambient temperature range .....	20
Measuring principle .....	6	Ambient temperature limits .....	20
Communication protocol .....	9	Storage temperature range .....	20
Measuring system .....	9	Vibration resistance .....	20
		Degree of protection .....	20
		Electromagnetic compatibility (EMC) .....	20
		Overvoltage protection .....	20
<b>Human interface</b> .....	<b>10</b>	<b>Operating conditions (process)</b> .....	<b>21</b>
Onsite display (optional) .....	10	Process temperature range .....	21
Operating elements .....	11	Process temperature limits .....	21
DAT module .....	11	Process pressure limits .....	21
Handheld terminals – HART .....	11		
FieldCare – HART, PROFIBUS PA .....	12	<b>Mechanical construction</b> .....	<b>21</b>
Commuwin II – HART, PROFIBUS PA .....	12	Dimensions of housing .....	21
Remote operation – FOUNDATION Fieldbus .....	12	Process connections DB50 and DB50A (compact version) .....	22
		Process connection DB50L and DB50S (food version) .....	25
		Process connections DB51 and DB51A (rod/pipe version) .....	27
		Dimensions of Deltapilot S DB52 and DB52A (cable version) ..	28
		Dimensions of Deltapilot S DB53 and DB53A	
		(suspension clamp and mounting bracket) .....	30
		Dimensions of connecting cable with	
		housing adapter and mounting bracket .....	31
		Weight .....	32
		Material .....	34
<b>Input (measured variable)</b> .....	<b>12</b>	<b>Certificates and approvals</b> .....	<b>35</b>
Measured variable .....	12	CE mark .....	35
Measuring range .....	12	Ex approvals .....	35
Explanation of terms .....	13	Overfill protection .....	35
		Seismic test .....	35
		Marine approval .....	35
		Standards and guidelines .....	35
<b>Output</b> .....	<b>14</b>	<b>Ordering information</b> .....	<b>36</b>
Output signal .....	14	DB50 – compact version .....	36
Signal on alarm .....	14	DB50L – compact version for hygienic applications .....	38
Load .....	14	DB51 – rod version .....	40
Sensitivity, PFM –FEB17(P) .....	14	DB52 – cable version with process connection .....	42
Damping .....	14	DB53 – cable version with suspension clamp .....	44
		DB50A – compact version .....	46
		DB50S – compact version for hygienic applications .....	48
		DB51A – rod version .....	50
		DB52A – cable version with process connection .....	52
		DB53A – cable version with suspension clamp .....	54
<b>Power supply</b> .....	<b>15</b>		
Electrical connection .....	15		
Supply voltage .....	16		
Current consumption .....	16		
Switch-on current .....	16		
Cable entry .....	16		
Cable specification .....	16		
Residual ripple .....	17		
<b>Performance characteristics</b> .....	<b>17</b>		
Reference operating conditions .....	17		
Position during calibration .....	17		
Zero-point increase .....	17		
Long-term stability .....	17		
Linearity .....	17		
Hysteresis .....	17		
Influence of ambient temperature .....	17		
Influence of medium temperature .....	17		
<b>Operating conditions (installation)</b> .....	<b>18</b>		
Installation instructions for compact version			
DB50, DB50A, DB50L, DB50S .....	18		
Installation instructions for rod and cable versions			
DB51(A), DB52(A) and DB53(A) .....	18		
Supplementary installation instructions .....	18		
Housing adapter with mounting bracket for humid, damp and			
difficult-to-access mounting locations .....	19		
Special measuring cells for substances with hydrogen formation	19		
Special measuring cell for acids, alkalis or sea water .....	19		

---

<b>Accessories</b> .....	<b>56</b>
Display and operating module FHB20 .....	56
Cover with sight glass (high cover) .....	56
Housing adapter with mounting bracket for humid, damp and difficult-to-access mounting locations .....	56
Mounting bracket .....	56
Extension cable shortening kit .....	56
Suspension clamp .....	56
Protective cover .....	57
Welding flanges .....	57
Welding neck adapter for universal process adapter .....	58
Welding neck adapter thread ISO G 1 1/2 .....	58
Adapter .....	58
<b>Documentation</b> .....	<b>59</b>
Field of Activities .....	59
Technical Information on switching unit .....	59
Operating Instructions .....	59
Safety Instructions .....	59
Installation Drawings/Control Drawings .....	59
Overfill protection .....	59

## Function and system design

### Device selection

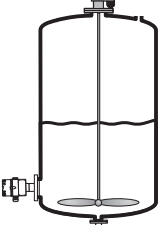
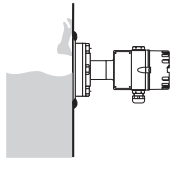
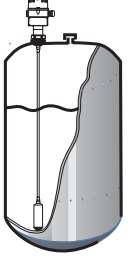
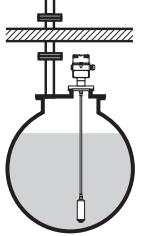
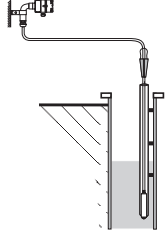
Deltapilot S – product family	DB50/DB50A  P01-DB5xxxxx-14-xx-xx-xx-001	DB50L/DB50S  P01-DB5xxxxx-14-xx-xx-xx-002	DB51/DB51A  P01-DB5xxxxx-14-xx-xx-xx-003	DB52/DB52A  P01-DB5xxxxx-14-xx-xx-xx-004	DB53/DB53A  P01-DB5xxxxx-14-xx-xx-xx-005
	<b>Compact version</b>	<b>Compact version as hygienic version</b>	<b>Rod version</b>	<b>Cable version</b>	<b>Cable version with suspension clamp</b>
Field of application	<ul style="list-style-type: none"> <li>– Level measurement</li> <li>– Differential pressure measurement (derived from level via switching unit)</li> </ul>				
Industries	Food, pharmaceutical, environment (fresh water and wastewater), chemical				
Process connections	<ul style="list-style-type: none"> <li>– Thread</li> <li>– Flanges</li> </ul>	<ul style="list-style-type: none"> <li>– Flush-mounted hygienic connections</li> </ul>	<ul style="list-style-type: none"> <li>– Thread</li> <li>– Flanges</li> </ul>	<ul style="list-style-type: none"> <li>– Thread</li> <li>– Flanges</li> </ul>	<ul style="list-style-type: none"> <li>– Suspension clamp</li> </ul>
Process connection material	<ul style="list-style-type: none"> <li>– AISI 316L</li> <li>– Alloy C4</li> </ul>	<ul style="list-style-type: none"> <li>– AISI 316L</li> </ul>	<ul style="list-style-type: none"> <li>– AISI 316L</li> <li>– Alloy C4</li> </ul>	<ul style="list-style-type: none"> <li>– AISI 316L</li> <li>– Alloy C4</li> </ul>	<ul style="list-style-type: none"> <li>– AISI 316L with plastic</li> </ul>
Rod (pipe)/ extension cable material	—	—	<ul style="list-style-type: none"> <li>– AISI 316L</li> <li>– Alloy C4</li> </ul>	<ul style="list-style-type: none"> <li>– FEP</li> <li>– PE</li> </ul>	<ul style="list-style-type: none"> <li>– FEP</li> <li>– PE</li> </ul>
Pipe/extension cable length	—	—	400 to 4000 mm (16 to 160 inch)	0.5 to 200 m (20 to 7874 inch) <sup>1</sup>	0.5 to 200 m (20 to 7874 inch) <sup>1</sup>
Measuring ranges	<ul style="list-style-type: none"> <li>– from –100 to +100 mbar to –900 to +10000 mbar</li> <li>– US version: from –1.5 to +1.5 psi to –13 to 150 psi</li> <li>– Max. turn down: 10:1</li> </ul>				
Process temperature	–10 to +100°C (+14 to +212°F)	–10 to +100°C (+14 to +212°F), +135°C (+275°F) for 30 minutes	–10 to +80°C (+14 to +176°F)	–10 to +80°C (+14 to +176°F)	–10 to +80°C (+14 to 176°F)
Supply voltage	<ul style="list-style-type: none"> <li>– Analog 0.2 to 1.2 mA: 15 to 20 V DC</li> <li>– PFM: 14 to 16 V DC; EEx ia: 14 to 19.2 V DC</li> <li>– 4 to 20 mA HART: 11.5 to 30 V DC; EEx ia: 11.5 to 30 V DC</li> <li>– PROFIBUS PA, version without overvoltage protection: 9 to 32 V DC; EEx ia: 9 to 24 V DC</li> <li>– Version with overvoltage protection: 9.6 to 32 V DC; EEx ia: 9 to 24 V DC</li> <li>– FOUNDATION Fieldbus: 9 to 32 V DC; EEx ia: 9 to 24 V DC</li> </ul>				
Output	0.2 to 1.2 mA, analog, PFM, 4 to 20 mA with superimposed HART protocol, PROFIBUS PA or FOUNDATION Fieldbus				
Options	<ul style="list-style-type: none"> <li>– 3.1 Inspection certificate</li> <li>– Separate housing</li> </ul>	<ul style="list-style-type: none"> <li>– 3.1 Inspection certificate</li> <li>– Separate housing</li> </ul>	<ul style="list-style-type: none"> <li>– Separate housing</li> </ul>	<ul style="list-style-type: none"> <li>– Separate housing</li> </ul>	—
Specialties	<ul style="list-style-type: none"> <li>– Absolutely resistant to condensate thanks to hermetically sealed CONTITE™ cell</li> <li>– Stainless steel version (AISI 316L) for hygienic requirements as well as aluminum and polyester housing versions</li> <li>– 3A and EHEDG approval</li> <li>– Maximum flexibility thanks to modular design</li> </ul>				

1) EExia, FM IS, CSA IS: 0.5 to 100 m (20 to 3937 inch)

### **DB50(A), DB51(A), DB52(A) universal usage**

- Modular probe program for optimum process adaptation
- DB50(A) compact version: installation in the tank from below or from the side
- DB51(A)/DB52(A) rod and cable extension: installation from above, i.e. easy to equip and retrofit buried tanks, no additional opening in the tank floor

### **DB50L/DB50S optimized for the food and pharmaceutical industry**

- All typical flush-mounted process connections can be supplied
- Welding flanges
- Stainless steel housing
- All food process connections are gap-free and can be cleaned without any residue left, e.g. CIP cleaning
- USDA/H1 approved transfer liquid as per FDA guidelines
- 3A or EHEDG approvals



P01-DB5xxxx-12-xx-xx-xx-004

### **DB53(A) for the water and wastewater industry**

- The housing with the electronic insert is mounted outside shafts and tanks in such a way that it is protected from flooding. The extension cable is secured with a suspension clamp.
- Electronic inserts with an integrated surge arrester provide protection against overvoltage if lightning strikes.
- The stainless steel measuring cell tube (AISI 316L) and the Alloy measuring diaphragm allow use in aggressive media such as wastewater for example.
- Extension cable up to 200 m in length (up to 100 m in Ex-areas) without strain relief.
- Special measuring cell with gold-rhodium coating for applications in which severe hydrogen formation can occur (e.g. digested sludge); see also Page 19.
- Special measuring cell with gold-platinum coating for acids, alkalis or sea water; see also Page 19.

## Measuring principle

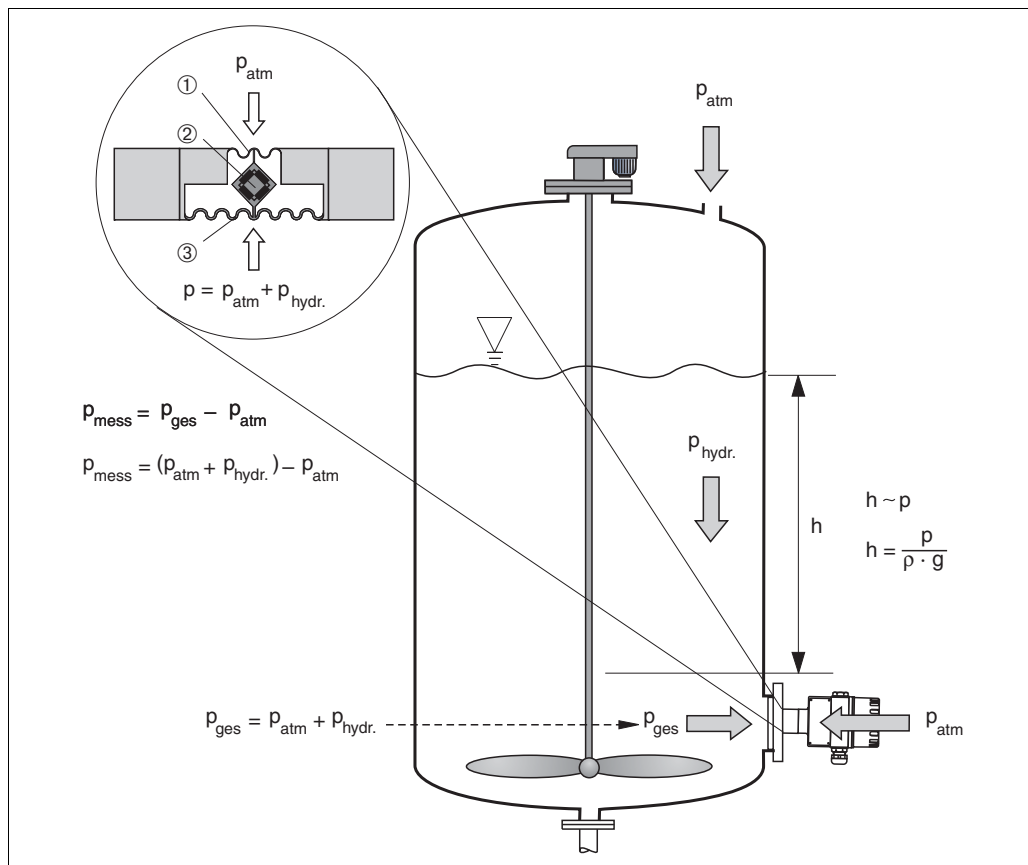

Deltapilot S hydrostatic level measurement and measuring principle

- 1 Measuring diaphragm  
 2 Measuring element  
 3 Process diaphragm (separating diaphragm)
- $g$  Gravitational acceleration  
 $h$  Level height  
 $p_{\text{tot}}$  Total pressure = hydrostatic pressure + atmospheric pressure  
 $p_{\text{atm}}$  Atmospheric pressure  
 $p_{\text{hydr.}}$  Hydrostatic pressure  
 $p_{\text{meas}}$  Measured pressure in the measuring cell = hydrostatic pressure  
 $\rho$  Density of fluid

Due to its weight, a liquid column creates hydrostatic pressure. If the density is constant, the hydrostatic pressure depends solely on the height  $h$  of the liquid column.

The CONTITE™ measuring cell which works on the principle of the gauge pressure sensor constitutes the core of Deltapilot S. In contrast to conventional gauge pressure sensors, the precision measuring element (2) in the CONTITE™ measuring cell is absolutely protected between the process diaphragm (3) and the measuring diaphragm (1). Thanks to this hermetic sealing of the measuring element, the CONTITE™ measuring cell is absolutely insensitive to condensate, condensation and aggressive gases. The pressure applied is transferred from the process diaphragm to the measuring element by means of an oil without any loss in pressure. Two temperature sensors are arranged between the process diaphragm and measuring element which measure the distribution of temperature in the cell. The electronics can compensate any measuring errors resulting from fluctuations in temperature with these temperature measured values.

### Level measurement in closed tanks with pressure overlay

You can determine the differential pressure in tanks with pressure overlay using two Deltapilot S probes. The pressure measured values of the two probes are sent to a signal processing unit such as Endress+Hauser RMA or a PLC. The signal processing unit or PLC determines the difference in pressure and uses this to calculate the level and the density where necessary.

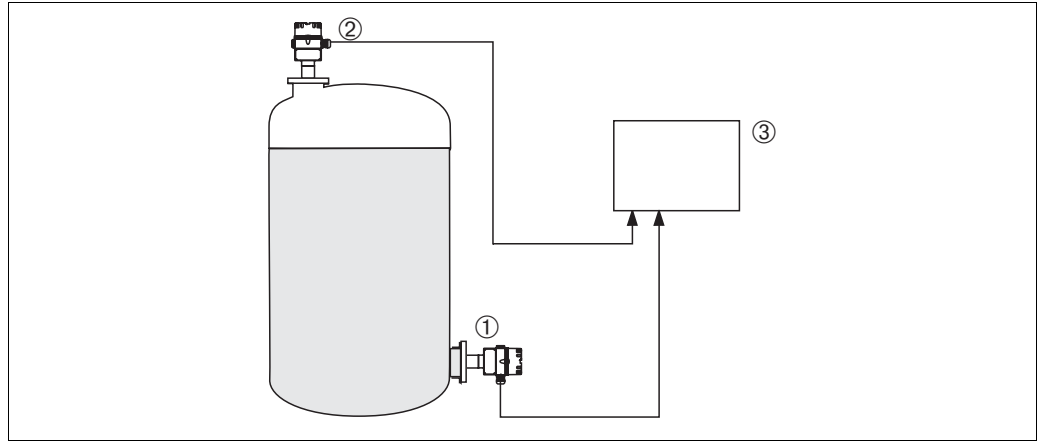

P01-DB5xxxx-15-xx-xx-xx-007

Level measurement in a closed tank with pressure overlay

- 1 Probe 1 measures the total pressure (hydrostatic pressure and top pressure)
- 2 Probe 2 measures the top pressure
- 3 The signal processing unit determines the difference in pressure and uses this to calculate the level

#### Note!

- When selecting the Deltapilot S probes, make sure you select large enough measuring ranges (→ see example).
- The measuring diaphragm of probe 2 must not be flooded. This generates additional hydrostatic pressure which distorts the measurement.
- The ratio of hydrostatic pressure to top pressure should be max. 1:6.

#### Example:

- Max. hydrostatic pressure = 600 mbar
- Max. top pressure (probe 2) = 300 mbar
- Max. total pressure, measured with probe 1 = 300 mbar + 600 mbar = 900 mbar  
⇒ Measuring cell to be selected: 0 to 1200 mbar
- Max. pressure, measured with probe 2: 300 mbar  
⇒ Measuring cell to be selected: 0 to 400 mbar

### Density measurement

You can measure the density in tanks with pressure overlay using two Deltapilot S probes and a signal processing unit or a PLC. The signal processing unit or the PLC calculates the density from the known distance  $\Delta h$  between the two probes and the two measured values  $p_1$  and  $p_2$ .

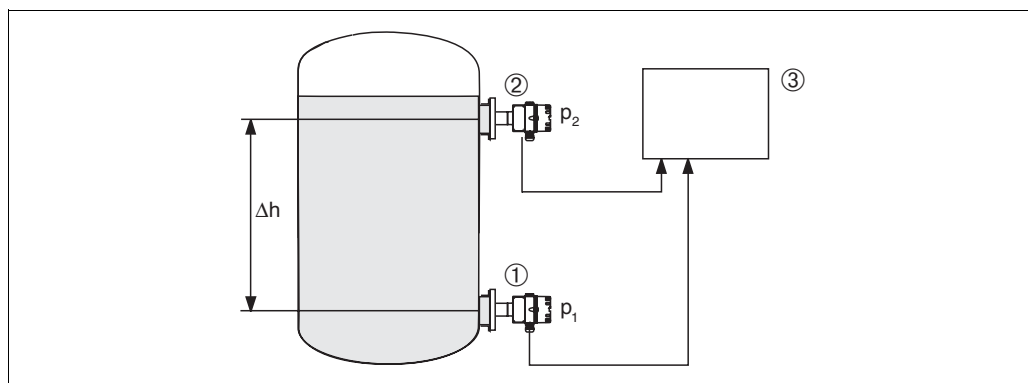

P01-DB5xxxxx-15-xx-xx-xx-005

Level measurement in a closed tank with pressure overlay

- 1 Deltapilot S determines pressure measured value  $p_1$
- 2 Deltapilot S determines pressure measured value  $p_2$
- 3 Signal processing unit determines the density from the two measured values  $p_1$  and  $p_2$  and the distance  $\Delta h$ .

### Level measurement with automatic density correction (with changing media in the tank)

Level measurement with automatic density correction is possible in conjunction with a limit switch such as Liquiphant and a PLC. The limit switch always switches at the same level. In the switch point, the signal processing unit determines the corrected density from the pressure of the Deltapilot S probe currently measured and the known distance between Deltapilot S and the limit switch. The signal processing unit then calculates the level from the new density and the measured pressure from the Deltapilot S probe.

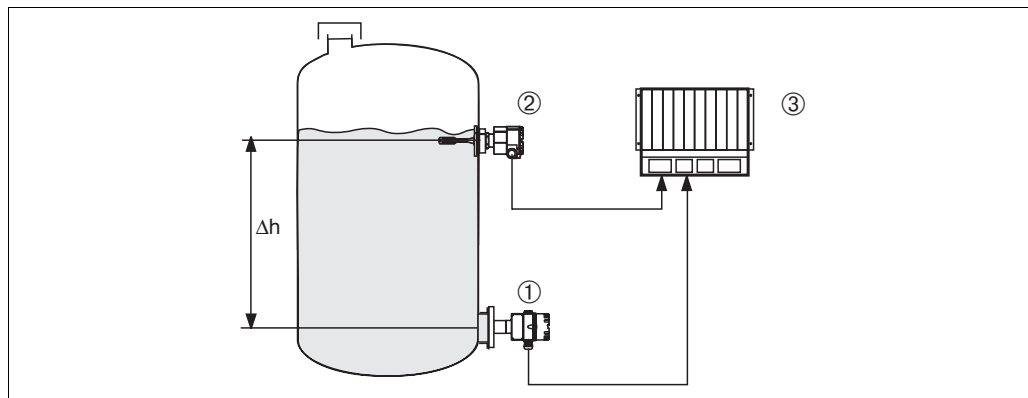

P01-DB5xxxxx-15-xx-xx-xx-005

Level measurement with automatic density correction

- 1 Deltapilot S
- 2 Liquiphant
- 3 PLC



**Communication protocol**

- 4 to 20 mA with HART communication protocol
- PROFIBUS PA
  - The Endress+Hauser Deltapilot S devices meet the FISCO model requirements.
  - Due to the low current consumption of  $10 \pm 1$  mA, the following can be operated at one bus segment with installation as per FISCO:
    - Up to 9 Deltapilot S for EEx ia, CSA IS and FM IS applications
    - Up to 32 Deltapilot S for all other applications, e.g. in non-hazardous areas, EEx nA, etc.Further information on PROFIBUS PA can be found in Operating Instructions BA034S "PROFIBUS DP/PA: Guidelines for planning and commissioning" and in the PNO guideline.
- FOUNDATION Fieldbus
  - The Endress+Hauser Deltapilot S devices meet the FISCO model requirements.
  - Due to the low current consumption of  $11 \pm 1$  mA, the following can be operated at one bus segment with installation as per FISCO:
    - Up to 9 Deltapilot S for EEx ia, CSA IS and FM IS applications
    - Up to 32 Deltapilot S for all other applications, e.g. in non-hazardous areas, EEx nA, etc.Further information on FOUNDATION Fieldbus such as bus system component requirements are provided in Operating Instructions BA013S "FOUNDATION Fieldbus Overview".

---

**Measuring system****Measuring system with 0.2 to 1.2 mA analog – FEB11(P)**

The electronic insert returns a current signal of 0.2 to 1.2 mA that is in proportion to the pressure. The FMC420 silometer provides voltage to the electronic insert and evaluates the current signal that is in proportion to the level. The standardized signals of 0 to 10 V and 4 to 20 mA (0 to 20 mA) are then available at the output of the silometer. → See also Technical Information TI077F and Operating Instructions BA179F.

**Measuring system with PFM – FEB17(P)**

The electronic insert returns a pulse-frequency-modulated signal of 200 to 1200 Hz. The evaluation and operating unit Prolevel FMB662 provides power to the electronic insert and converts the PFM signal of the probe to a standardized current or voltage signal. → See also Technical Information TI234F and Operating Instructions BA144F.

**Measuring system with 4 to 20 mA HART – FEB22(P)**

HART is a field-tested industry standard accepted worldwide. In HART technology, the 4 to 20 mA analog transmission and the digital communication take place simultaneously via the same wire pair. The 4 to 20 mA analog signal is used for rapid measured value transmission. The digital HART signal allows device data to be read and written, e.g. for diagnosis and maintenance information.

**Measuring system with PROFIBUS PA – FEB24(P)**

PROFIBUS PA is an open fieldbus standard. It allows multiple sensors and actuators to be connected, even in Ex-areas. By means of PROFIBUS PA, energy is supplied to the devices with two-wire technology and the process information is transmitted digitally from the sensor. Further information on PROFIBUS PA, such as bus system component requirements, can be found in Operating Instructions BA034S "PROFIBUS DP/PA: Guidelines for planning and commissioning" and in the PNO guideline.

**Measuring system with FOUNDATION Fieldbus – FEB26**

FOUNDATION Fieldbus is an open fieldbus standard. It allows multiple sensors and actuators to be connected, even in Ex-areas. By means of FOUNDATION Fieldbus, energy is supplied to the devices with two-wire technology and the process information is transmitted digitally from the sensor. Further information on FOUNDATION Fieldbus such as bus system component requirements are provided in Operating Instructions BA013S "FOUNDATION Fieldbus Overview".

## Human interface

### Onsite display (optional)

The FHB20 display and operating module is available as an option for the following electronic inserts. → See also Page 37, feature 70 "Electronic insert":

- 4 to 20 mA HART – FEB22(P)
- PROFIBUS PA – FEB24(P)
- FOUNDATION Fieldbus – FEB26

The parameters are illustrated in a 10 x 10 matrix (→ see Figure, No. ④). With the display module, you can access every parameter directly at the place of measurement. Dry calibration, linearization and operation enabling and disabling are possible without any further tools.

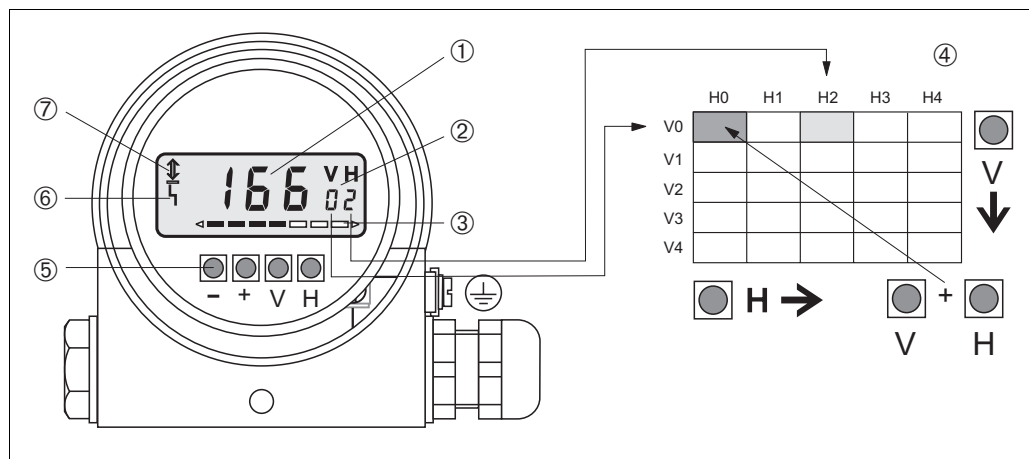

P01-DB5xxxxx-07-xx-xx-xx-001

User interface of the electronic insert with the FHB20 display and operating module

- 1 4 1/2-digit display of measured values and parameters
- 2 Current matrix position
- 3 Bar graph of the measured value
- 4 Operating matrix
- 5 Operating keys
- 6 Signal for reporting an error
- 7 Communication signal, lights up when operating using the handheld terminal or via remote operation

Operating elements

Operating keys and elements on the electronic insert

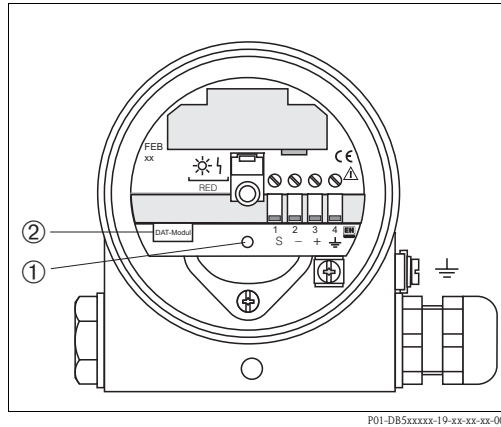

Electronic insert FEB11(P) – 0.2 to 1.2 mA and electronic insert FEB17(P) – PFM

- 1 Red LED to indicate a fault
- 2 Slot for the DAT module

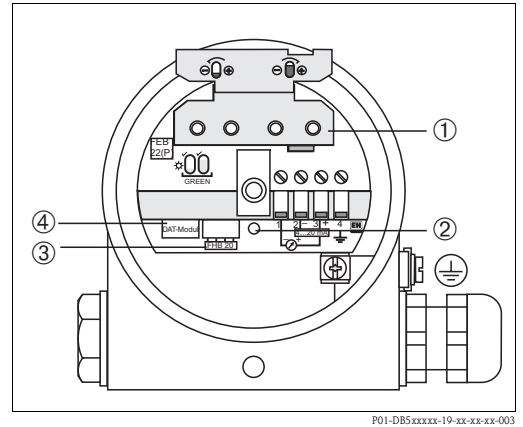

Electronic insert FEB22(P) – 4 to 20 mA HART

- 1 Operating keys for empty and full calibration, calibration with partially full tanks, lock/unlock operation and reset
- 2 Green LED flashes when accepting the value for empty and full calibration, during a reset and if operation is locked or unlocked
- 3 Slot for optional FHB20 display and operating module
- 4 Slot for the DAT module

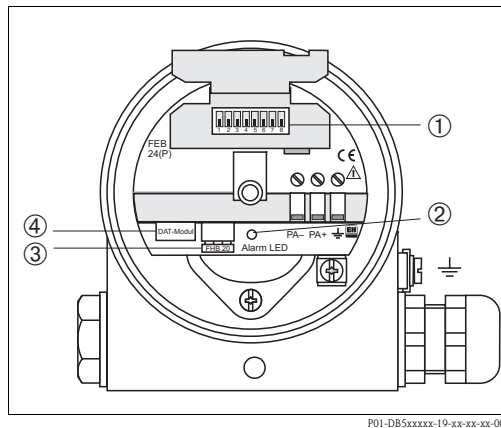

Electronic insert FEB24(P) – PROFIBUS PA

- 1 DIP switches for bus address
- 2 Red LED to indicate a warning or a fault
- 3 Slot for optional FHB20 display and operating module
- 4 Slot for the DAT module

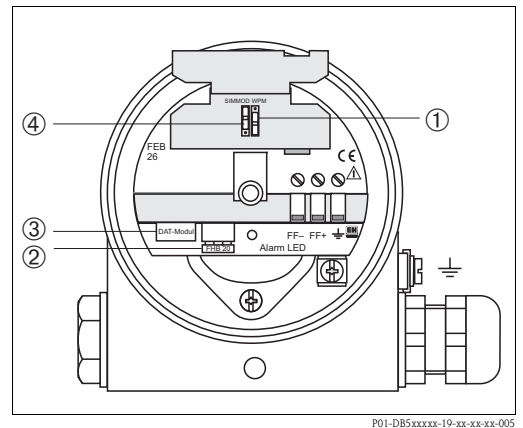

Electronic insert FEB26 – FOUNDATION Fieldbus

- 1 DIP switch to lock/unlock operation
- 2 Slot for optional FHB20 display and operating module
- 3 Slot for the DAT module
- 4 DIP switch for switching simulation mode on/off

DAT module

All the specific data of the measuring cell are saved in the DAT module. When the device is switched on, these data are read out of the DAT module and into the electronic insert memory.

The DAT module can be ordered as a spare part (order number: 542585-0000). However, the measuring cell number must be stated when ordering.

Handheld terminals – HART

With the handheld terminal Universal-HART-Communicator DXR275 or DXR375, all the parameters can be configured anywhere along the 4 to 20 mA line via menu operation.

**FieldCare –  
HART, PROFIBUS PA**

FieldCare is an Endress+Hauser asset management tool based on FDT technology. With FieldCare, you can configure all Endress+Hauser devices as well as devices from other manufacturers that support the FDT standard. The following operating systems are supported: WinNT4.0, Win2000 and Windows XP.

FieldCare supports the following functions:

- Configuration of transmitters in offline and online operation
- Loading and saving device data (upload/download)
- Documentation of the measuring point

**Commuwin II –  
HART, PROFIBUS PA**

Commuwin II is a graphically supported operating program for intelligent measuring devices with the communication protocols HART and PROFIBUS PA. The following operating systems are supported: Win 3.1/3.11, Win 95, Win 98, WinNT4.0 and Win2000.

Commuwin II supports the following functions:

- Configuration of measuring devices in online operation via matrix operation
- Loading and saving device data (upload/download)
- Visualization of measured values and limit values
- Presentation and recording of measured values with a line recorder.

Connection option:

- HART via Commubox FXA191 with the serial interface RS 232 C of a computer or via Commubox FXA195 with the USB interface of a computer
- PROFIBUS PA via segment coupler and PROFIBUS interface card

**Remote operation –  
FOUNDATION Fieldbus**

An FF configuration program is required to integrate a device with "FOUNDATION Fieldbus signal" into an FF network or to set the FF-specific parameters. Please contact your local Endress+Hauser Sales Center for more information.

## Input (measured variable)

**Measured variable**                      Hydrostatic pressure

**Measuring range**

Measuring range	Measuring limit		Recommended span min./max. [bar]	Overload  $\text{bar}_{\text{abs}}$	Vacuum resistance  bar	Version in the order code <sup>1</sup>
	lower (LRL) [bar]	upper (URL) [bar]				
0 to +100 mbar	0	+0.1	0.025/0.1	8	-0.1	BA
0 to +400 mbar	0	+0.4	0.04/0.4	8	-0.4	BB
0 to +1200 mbar	0	+1.2	0.12/1.2	24	-0.9	BC
0 to +4 bar	0	+4	0.4/4	24	-0.9	BD
0 to +10 bar	0	+10	1/10	40	-0.9	BE
-100 to +100 mbar	-0.1	+0.1	0.025/0.1	8	-0.1	DA
-400 to +400 mbar	-0.4	+0.4	0.04/0.4	8	-0.4	DB
-900 to +1200 mbar	-0.9	+1.2	0.12/1.2	24	-0.9	DC
-900 to +4000 mbar	-0.9	+4	0.4/4	24	-0.9	DD
-0.9 to +10 bar	-0.9	+10	1/10	40	-0.9	DE

1) See also Page 36 ff, "Ordering information" chapter, feature 40 "Measuring range"

**Explanation of terms**

- A turn down of TD = 10:1 is possible with the following electronic inserts:
  - 4 to 20 mA HART – FEB22(P)
  - PROFIBUS PA – FEB24(P)
  - FOUNDATION Fieldbus – FEB26

Turn down is possible via the signal processing units for electronic inserts 0.2 to 1.2 mA analog – FEB11(P) and PFM – FEB17(P). → See "Function and system design" chapter, "Measuring device" section.

**Explanation of terms: turn down (TD), set span and span based on zero point**

Case 1:

- $| \text{Lower range value (LRV)} | \leq | \text{Upper range value (URV)} |$

Example:

- Lower range value (LRV) = 0 mbar
- Upper range value (URV) = 40 mbar
- Nominal value (URL) = 400 mbar

Turn down:

- $\text{Nominal value} / | \text{upper range value (URV)} | = 400 \text{ mbar} / 40 \text{ mbar}$   
TD = 10:1

Set span:

- $\text{Upper range value (URV)} - \text{lower range value (LRV)} = 40 \text{ mbar} - 0 \text{ mbar}$   
Set span = 40 mbar  
This span is based on the zero point.

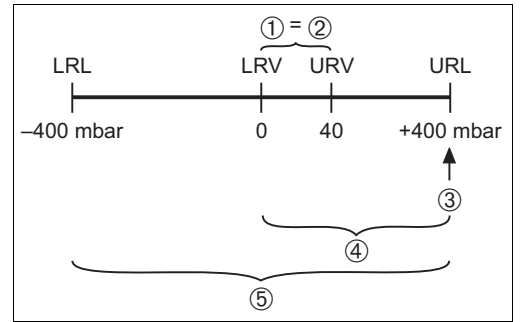

P01-DBxxxxxx-05-xx-xx-xx-001

Example: 400 mbar measuring cell

Case 2:

- $| \text{Lower range value (LRV)} | \geq | \text{Upper range value (URV)} |$

Example:

- Lower range value (LRV) = -200 mbar
- Upper range value (URV) = 0 mbar
- Nominal value (URL) = 400 mbar

Turn down:

- $\text{Nominal value} / | \text{lower range value (LRV)} | = 400 \text{ mbar} / 200 \text{ mbar}$   
TD 2:1

Set span:

- $\text{Upper range value (URV)} - \text{lower range value (LRV)} = 0 \text{ mbar} - (-200 \text{ mbar})$   
Set span = 200 mbar  
This span is based on the zero point.

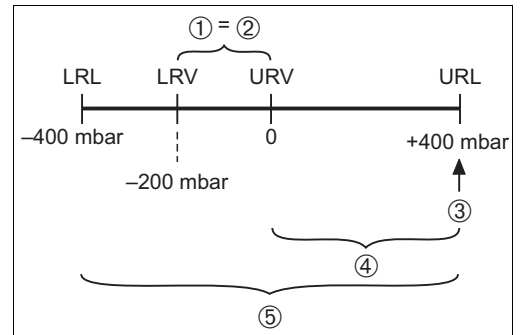

P01-DBxxxxxx-05-xx-xx-xx-002

Example: 400 mbar measuring cell

- 1 Set span
  - 2 Span based on zero point
  - 3 Nominal value  $\cong$  upper range limit (URL)
  - 4 Nominal measuring range
  - 5 Sensor measuring range
- LRL Lower range limit  
URL Upper range limit  
LRV Lower range value  
URV Upper range value

## Output

### Output signal

- 0.2 to 1.2 mA analog signal, 3-wire
- 200 to 1200 Hz PFM signal, 2-wire
  - $f_0 = 200 \text{ Hz} \pm 5 \text{ Hz}$
  - 100 mbar measuring range:  $f_0 = 200 \text{ Hz} \pm 10 \text{ Hz}$
- 4 to 20 mA with superimposed communication protocol HART, 2-wire
- Digital communication signal PROFIBUS PA (Profile 3.0), 2-wire
- Digital communication signal FOUNDATION Fieldbus, 2-wire

### Signal on alarm

- 0.2 to 1.2 mA analog:  $\geq 1.5 \text{ mA}$
- PFM  $\leq 20 \text{ Hz}$
- 4 to 20 mA HART
  - Options:
    - Min. = 3.6 mA; onsite display: 0
    - Max. = 22 mA (factory setting); onsite display: 1
    - Hold: last measured value is held; onsite display: 2
- PROFIBUS PA:
  - Options configurable in the Analog Input Block for the output signal: Last Valid Out Value, FSafe Value (factory setting), Status bad
  - Options configurable in the Transducer Block for the "Measured value" parameter and the onsite display: Min. (onsite display: -19999), Max. (onsite display: +19999), Hold: last measured value is held
- FOUNDATION Fieldbus:
  - Output signal: last measured value is held; status change from "Uncertain" or "Bad"
  - Options configurable in the Transducer Block for the "Measured value" parameter and the onsite display: Min. (onsite display: -19999), Max. (onsite display: +19999), Hold: last measured value is held

### Load

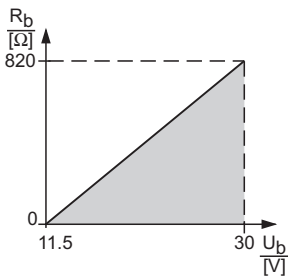
0.1 to 1.2 mA analog	PFM	4 to 20 mA HART
Max. 25 $\Omega$ /core	Max. 25 $\Omega$ /core	 <p style="text-align: right; font-size: small;">P01-DB5xxxxx-05-xx-xx-xx-002</p>

### Sensitivity, PFM –FEB17(P)

Measuring range	Resolution	Measuring range	Resolution
0 to 100 mbar	10 Hz/mbar	-100 to 100 mbar	5 Hz/mbar
0 to 400 mbar	2.5 Hz/mbar	-400 to 400 mbar	1.25 Hz/mbar
0 to 1200 mbar	0.833 Hz/mbar	-900 to 1200 mbar	0.476 Hz/mbar
0 to 4000 mbar	0.25 Hz/mbar	-900 to 4000 mbar	0.204 Hz/mbar
0 to 10000 mbar	0.1 Hz/mbar	-900 to 10000 mbar	0.092 Hz/mbar

### Damping

- 0 to 99 s configurable via the FHB20 display and operating module, PC with operating program or handheld terminal
- Factory setting: 0 s

## Power supply

### Electrical connection

Note!

- When using the measuring device in hazardous areas, installation must comply with the corresponding national standards and regulations and the Safety Instructions (XAs) or Installation or Control Drawings (ZDs). → See also Page 59 ff, "Safety Instructions" and "Installation/Control Drawings" sections.
- Protective circuits against reverse polarity and HF influences are integrated.
- The housing must be grounded for electronic inserts with an integrated overvoltage protection.
- The system is optimally shielded against interference influences if the shielding is connected on both sides. If you have to reckon with potential equalization currents in the system, only ground the shielding at one end, preferably at the Deltapilot S probe.

### 4 to 20 mA HART electronics – FEB22(P)

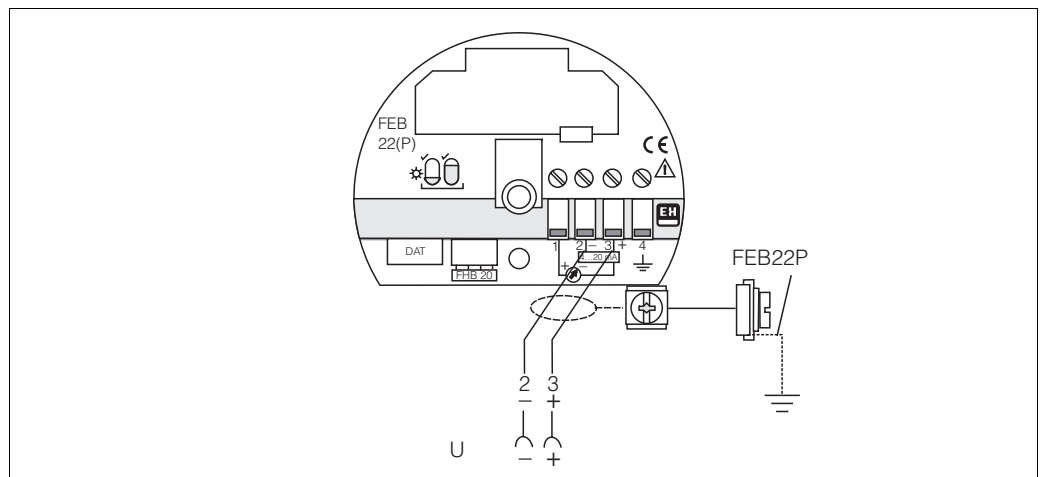

P01-DB5xxxx-04-xx-xx-xx-005

### 0.2 to 1.2 mA analog electronics – FEB11(P)

The twin-core cable must be connected to terminals 2 (-) and 3 (+).

### PFM electronics – FEB17(P)

The twin-core cable must be connected to terminals 2 (-) and 3 (+).

### PROFIBUS PA electronics – FEB24(P)

The twin-core cable must be connected to the "PA+" and "PA-" terminal.

More information on laying out and grounding the network is provided in Operating Instructions BA034S "PROFIBUS DP/PA: Guidelines for planning and commissioning".

### FOUNDATION Fieldbus electronics – FEB26

The twin-core cable must be connected to the "FF+" and "FF-" terminal.

More information on laying out and grounding the network is provided in Operating Instructions BA013S "FOUNDATION Fieldbus Overview".

<b>Supply voltage</b>	<p>Note!</p> <ul style="list-style-type: none"> <li>■ When using the measuring device in hazardous areas, installation must comply with the corresponding national standards and regulations and the Safety Instructions (XAs) or Installation or Control Drawings (ZDs).</li> <li>■ All explosion protection data are given in separate documentation which is available upon request. The Ex documentation is supplied as standard with all devices approved for use in explosion hazardous areas. → See also Page 59 ff, "Safety Instructions" and "Installation/Control Drawings" sections.</li> </ul> <p><b>0.2 to 1.2 mA analog</b></p> <p>15 to 20 V DC</p> <p><b>PFM</b></p> <p>Version for non-hazardous areas: 14 to 16 V DC</p> <p><b>4 to 20 mA HART</b></p> <p>Version for non-hazardous areas: 11.5 to 30 V DC</p> <p><b>PROFIBUS PA</b></p> <ul style="list-style-type: none"> <li>■ Version for non-hazardous areas and electronics without overvoltage protection: 9 to 32 V DC</li> <li>■ Version for non-hazardous areas and electronics with overvoltage protection: 9.6 to 32 V DC</li> </ul> <p><b>FOUNDATION Fieldbus</b></p> <p>Version for non-hazardous areas: 9 to 32 V DC</p>
<b>Current consumption</b>	<p><b>PROFIBUS PA</b></p> <p>10 mA ± 1 mA</p> <p><b>FOUNDATION Fieldbus</b></p> <p>11 mA ± 1 mA</p>
<b>Switch-on current</b>	<p><b>0.1 to 1.2 mA analog, PFM and 4 to 20 mA HART</b></p> <p>100 mA for 30 V, pulse width half-life 20 ms</p> <p><b>PROFIBUS PA and FOUNDATION Fieldbus</b></p> <p>Switch-on current corresponds to Table 4, IEC 611158-2, Clause 2</p>
<b>Cable entry</b>	<p>→See also Page 37 ff, feature 80 "Housing; Cable entry".</p>
<b>Cable specification</b>	<p><b>0.1 to 1.2 mA analog</b></p> <ul style="list-style-type: none"> <li>■ Endress+Hauser recommends using a shielded, three-core instrument cable with max. 25 Ω per core.</li> <li>■ Terminals for wire cross-section: 0.08 to 2.5 mm<sup>2</sup></li> </ul> <p><b>PFM</b></p> <ul style="list-style-type: none"> <li>■ Endress+Hauser recommends using a shielded, twin-core instrument cable with max. 25 Ω per core.</li> <li>■ Terminals for wire cross-section: 0.08 to 2.5 mm<sup>2</sup></li> </ul> <p><b>4 to 20 mA HART, PROFIBUS PA and FOUNDATION Fieldbus</b></p> <ul style="list-style-type: none"> <li>■ Endress+Hauser recommends using a twisted, shielded twin-core cable.</li> <li>■ Terminals for wire cross-section: 0.08 to 2.5 mm<sup>2</sup></li> </ul>



**Residual ripple**

**4 to 20 mA HART**

- Max. ripple (measured at 500 Ω) 47 to 125 kHz:  $U_{ss} \leq 200 \text{ mV}$
- Max. noise (measured at 500 Ω) 500 Hz to 10 kHz:  $U_{eff} \leq 2.2 \text{ mV}$

**0.1 to 1.2 mA analog**

In the range 1 Hz to 100 kHz: max. failsafe value  $U_{ss} \leq 1 \text{ V}$

## Performance characteristics

**Reference operating conditions**

- As per DIN 16086
- Calibration temperature: +25°C (+77°F)

**Position during calibration**

- ① DB50(A), DB50L, DB50S
- ② DB51(A), DB 52(A), DB53(A)

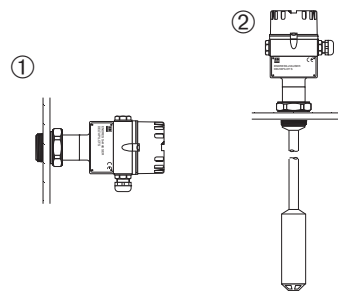

P01-DB5xxxxx-11-xx-xx-xx-009

**Zero-point increase**

90% of measuring range

**Long-term stability**

$\pm 0.1\%$  of URL<sup>1</sup> per 6 months

**Linearity**

Linearity as per the limit point method:  
 –  $\pm 0.2\%$  of the set span<sup>1</sup>  
 – Optional:  $\pm 0.1\%$  of the set span<sup>1</sup>

**Hysteresis**

$\pm 0.1\%$  of URL<sup>1</sup>

**Influence of ambient temperature**

$\pm 0.01\%/10 \text{ K}$  of URL<sup>1</sup>

**Influence of medium temperature**

$\pm 0.1\%/10 \text{ K}$  of URL<sup>1</sup>

1) For an explanation of terms, see Page 13

## Operating conditions (installation)

### Installation instructions for compact version DB50, DB50A, DB50L, DB50S

- Always install the device under the lowest measuring point.
- Do not install the device at the following positions:
  - In the filling curtain, in the tank outlet or at a point in the tank that can be reached by pressure pulses from the agitator.
- The calibration and functional test can be carried out more easily if you mount the device after a shut-off device.
- Deltapilot S must be included in the insulation for media that can harden when cold. The use of rod or cable versions is also possible.

### Installation instructions for rod and cable versions DB51(A), DB52(A) and DB53(A)

- When mounting the rod and cable versions, make sure that the probe head is located at a point as free as possible from flow. To protect the probe from impact from lateral movement, mount the probe in a guide tube (preferably made of plastic) or secure it with a clamping fixture. For devices for Ex-areas, see Safety Instructions (XAs).
- The length of the extension cable or the probe rod is based on the planned level zero point. The top of the probe should be at least 5 cm under this.

### Supplementary installation instructions

#### Process diaphragm

- Do not use sharp or hard objects to handle or clean the process diaphragm. Build-up has no effect on the measurement result as long it is porous and does not present a mechanical load on the diaphragm of the pressure measuring cell.
- The process diaphragm on all Deltapilot S rod and cable extension is protected against mechanical damage by means of a plastic cover.

#### Seal

- Deltapilot S with G 1 1/2 thread:
  - When screwing the device into the tank, the flat seal supplied must be placed on the sealing surface of the process connection.
- Deltapilot S with NPT thread:
  - Wrap and seal the thread with Teflon tape.
  - Tighten the device at the hexagon head only. Do not turn the device by the housing.
  - Do not screw in the thread too tightly. Max. torque: 20...30 Nm

#### Sealing the probe housing

It is important that no moisture enters the housing while mounting the probe, connecting the electronic insert and operating the measuring system.

- Always screw the housing cover and the cables entries tight.
- The O-Ring seal in the housing cover and the thread of the aluminum cover are lubricated. If this lubrication has been removed, replace it with silicone grease or graphite paste, for example, so that the cover seals tight. Do not use mineral-oil based greases. These can destroy the O-ring.

### Housing adapter with mounting bracket for humid, damp and difficult-to-access mounting locations

With the housing adapter and mounting bracket, you have the option of mounting the housing with the electronic insert away from the measuring point. This allows problem-free measurement

- under particularly difficult measuring conditions (in confined or difficult-to-access mounting locations)
- in the event of extreme fluctuations in temperature at the tank wall.

You can operate and control the device quickly and comfortably away from the measuring point by means of the FHB20 display and operating module or via remote operation. IP 68 ingress protection applies for the housing adapter.

The mounting bracket is suitable for pipe and wall mounting.

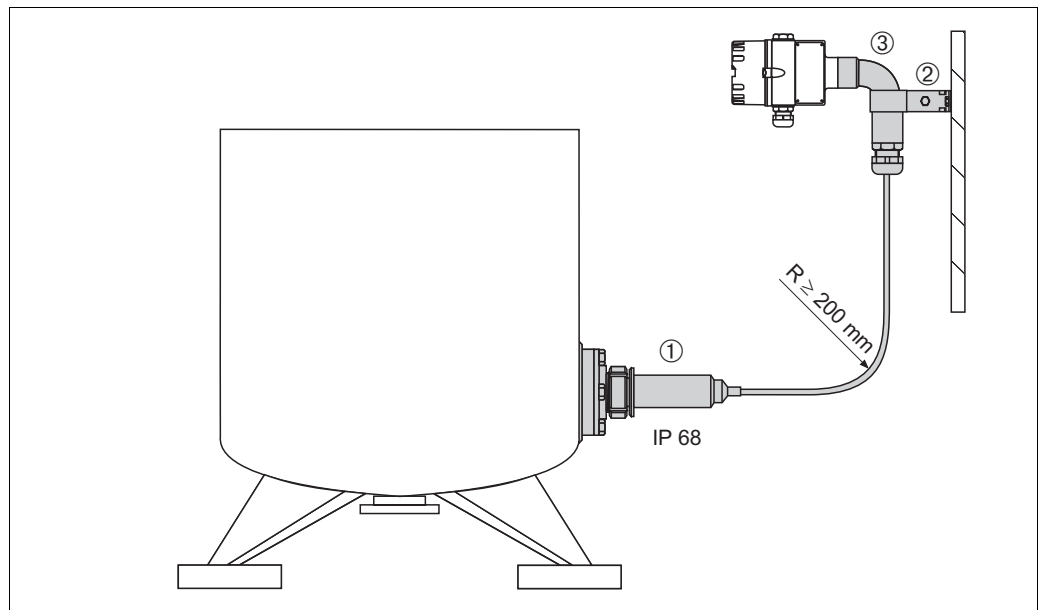

P01-DB5xxxx-11-xx-xx-xx-006

Measuring point with housing adapter and mounting bracket

- 1 Housing adapter
- 2 Mounting bracket for pipe and wall mounting
- 3 Pipe bend

Note!

- When mounting, observe a bending radius of at least 200 mm.

### Special measuring cells for substances with hydrogen formation

In the case of materials in which hydrogen formation occurs (e.g. digested sludge), hydrogen atoms can diffuse through the metal diaphragm. This can result in incorrect measurement results.

For such instances, Endress+Hauser offers diaphragms with a gold-rhodium coating.

→ Order through 50 "Measuring cell version", type Z "Additional specification". In addition, for version "Z", quote the order number 52009331.

Note!

- To reduce the formation of hydrogen, you should refrain from using galvanized assemblies.

### Special measuring cell for acids, alkalis or sea water

For acids, alkalis or sea water, Endress+Hauser offers diaphragms with a gold-platinum coating.

→ Order through 50 "Measuring cell version", type Z "Additional specification". In addition, indicate the order number 52009332 for Version 'Z'.

## Operating conditions (environment)

<b>Ambient temperature range</b>	<ul style="list-style-type: none"> <li>■ -20 to +60°C (-4 to +140°F)</li> <li>■ With separate electronics: -20 to +85°C (-4 to +185°F)</li> </ul> <p>For devices for use in hazardous areas, see Safety Instructions (XAs), Installation or Control Drawing (ZDs).</p>
<b>Ambient temperature limits</b>	<p>-40 to +85°C (-40 to +185°F)</p> <p>The device can be operated in this temperature range. When commissioning the device, the temperature cannot go below -20°C (-4°F). The values of the specification such as accuracy can be overshoot here.</p>
<b>Storage temperature range</b>	-40 to +85°C (-40 to +185°F)
<b>Vibration resistance</b>	10 to 55 Hz, 2 g, as per DIN EN 60068-2-6
<b>Degree of protection</b>	<ul style="list-style-type: none"> <li>■ → See Page 37 ff, feature 80 "Housing; Cable entry".</li> <li>■ Housing: IP 66/NEMA 4X</li> <li>■ Housing adapter: IP 68 (1 mH<sub>2</sub>O for 24 h)</li> </ul>
<b>Electromagnetic compatibility (EMC)</b>	Interference emission as per EN 61326, electrical device B; interference immunity as per EN 61326 appendix A (industrial use) and NAMUR EMC recommendation (NE21).
<b>Overvoltage protection</b>	<p>The following electronic inserts are equipped with an surge arrester:</p> <ul style="list-style-type: none"> <li>- 0.2 to 1.2 mA analog – FEB11P</li> <li>- PFM – FEB17P</li> <li>- 4 to 20 mA HART – FEB22P</li> <li>- PROFIBUS PA – FEB24P</li> </ul> <p>Protective diodes: gas tube surge arrester 230 V, nominal discharge current 10 kA</p>

## Operating conditions (process)

### Process temperature range

Device	Process temperature range
<ul style="list-style-type: none"> <li>– DB50(A)</li> <li>– DB50L, DB50S</li> </ul>	–10 to +100°C (+14 to +212°F)
<ul style="list-style-type: none"> <li>– DB51(A)</li> <li>– DB52(A) with FEP extension cable</li> <li>– DB53(A) with FEP extension cable</li> </ul>	–10 to +80°C (+14 to +176°F)
<ul style="list-style-type: none"> <li>– DB52(A) with PE extension cable</li> <li>– DB53(A) with PE extension cable</li> </ul>	–10 to +70°C (+14 to +158°F)

For devices for use in hazardous areas, see Safety Instructions (XAs), Installation or Control Drawing (ZDs).

### Process temperature limits

- DB51(A), DB52(A) and DB53(A): –40 to +85°C (–40 to +185°F)
- The DB50L and DB50S versions can be exposed to +135°C (+275°F) for a brief period (maximum 30 minutes) for cleaning purposes.

### Process pressure limits

→ For overload and vacuum resistance see Page 12, "Measuring range" section.

## Mechanical construction

### Dimensions of housing

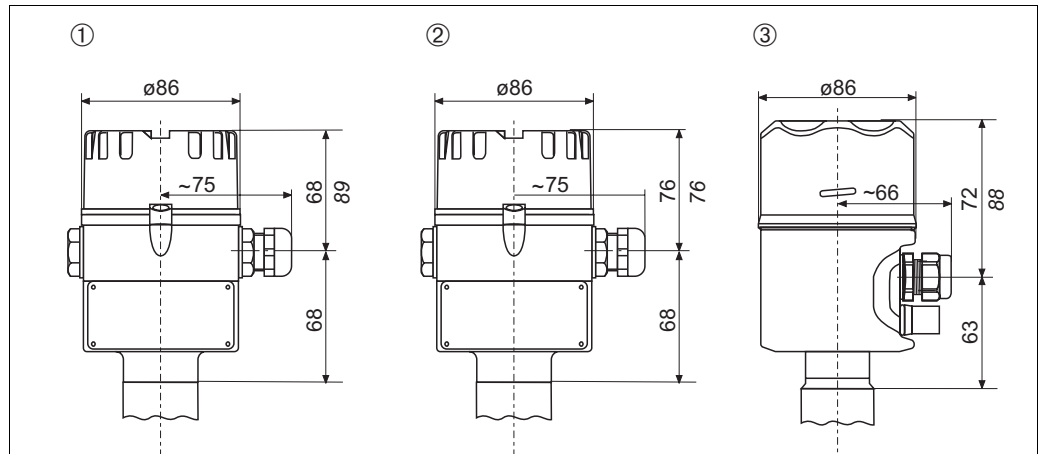

*Deltapilot S housing versions*

- 1 *Aluminum housing*
- 2 *Polyester housing*
- 3 *Stainless steel housing*

*Dimensions written in italics apply to devices with a cover including a sight glass. Devices with the FHB20 onsite display are always supplied with a cover with a sight glass.*

Process connections DB50 and DB50A (compact version) Threaded connection ISO 228 and NPT

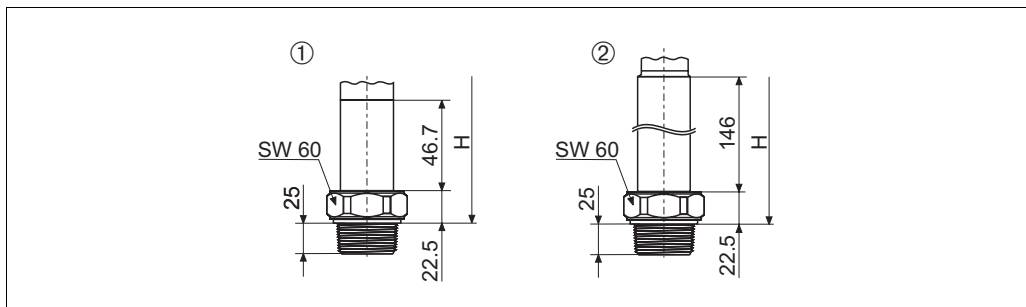

F01-DB5xxxxx-06-xx-xx-xx-023

DB50(A) with thread

- 1 DB50(A) with thread G 1 1/2 or 1 1/2 NPT without flame barrier
- 2 DB50(A) with thread G 1 1/2 or 1 1/1 NPT with flame barrier  
(flame barrier for use in hazardous areas, Zone 0)

Installation height H, devices with a thread

	Cover	Aluminum housing [mm]	Polyester housing [mm]	Stainless steel housing [mm]
Without a flame barrier	Flat	205.2	213.2	204.2
	High (with sight glass) <sup>1</sup>	226.2	213.2	220.2
With a flame barrier	Flat	304.5	312.5	204.2
	High (with sight glass) <sup>1</sup>	325.5	312.5	231.5

- 1) Devices with the FHB20 display and operating module are always supplied with a high cover or with a cover with a sight glass.

EN/DIN, ANSI and JIS flanges

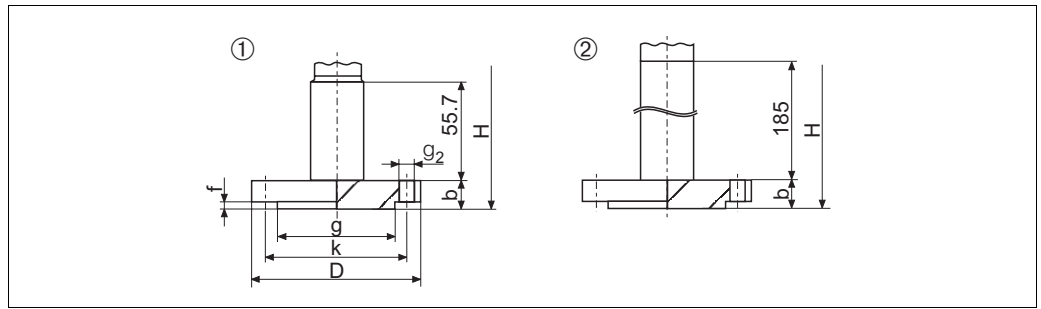

P01-DB5xxxx-06-xx-xx-xx-024

DB50(A) with flange; surface roughness of the surfaces in contact with the medium EN/DIN:  $R_a = 10$  to  $12.5 \mu m$ , ANSI:  $R_a = 3.2$  to  $6.3 \mu m$ , JIS:  $R_a = 3.2$  to  $6.3 \mu m$

- 1 DB50(A), flange without flame barrier
- 2 DB50(A), flange with flame barrier (flame barrier for use in hazardous areas, Zone 0)
- H For installation height H, see Page 24

EN/DIN flanges, connection dimensions as per EN 1092-1 (old DIN 2526 Form C)

Version	Flange								Screwholes			Flange weight <sup>3</sup>
	Material <sup>1</sup>	Nominal diameter	Nominal pressure	Shape <sup>2</sup>	Diameter	Thick-ness	Raised face diameter	Raised face height	Quantity	Diameter	Hole circle	
					D [mm]	b [mm]	g [mm]	f [mm]		g <sub>2</sub> [mm]	k [mm]	
20	AISI 316L	DN 40	PN 10/16	B1 (C)	150	16	88	3	4	18	110	2.3
21	AISI 316L	DN 50	PN 10/16	B1 (C)	165	18	102	3	4	18	125	3.0
22	AISI 316L	DN 80	PN 10/16	B1 (C)	200	24	138	3	8	18	160	4.8
23	AISI 316L	DN 100	PN 10/16	B1 (C)	220	20	158	3	8	18	180	6.0

- 1) AISI 316L/1.4435
- 2) Designation as per DIN 2526 in brackets
- 3) Housing weight, see Page 32

ANSI flanges, connection dimensions as per ANSI B 16.5, raised face RF

Version	Flange								Screwholes			Flange weight <sup>2</sup>
	Material <sup>1</sup>	Nominal diameter	Class	Diameter	Thickness	Raised face diameter	Raised face height	Quantity	Diameter	Hole circle		
		[in]	[lb./sq in]	D [in] [mm]	b [in] [mm]	g [in] [mm]	f [in] [mm]		g <sub>2</sub> [in] [mm]	k [in] [mm]	[kg]	
30	AISI 316/ 316L	1 1/2	150	5 127	0.69 17.5	2.88 73.2	0.06 1.6	4	0.62 15.7	3.88 98.6	1.8	
31	AISI 316/ 316L	2	150	6 152.4	0.75 19.1	3.62 91.9	0.06 1.6	4	0.75 19.1	4.75 120.7	2.7	
32	AISI 316/ 316L	3	150	7.5 190.5	0.94 23.9	5 127	0.06 1.6	4	0.75 19.1	6 152.4	5.4	
33	AISI 316/ 316L	4	150	9 228.6	0.94 23.9	6.19 157.2	0.06 1.6	8	0.75 19.1	7.5 190.5	7.5	

- 1) Combination of AISI 316 for required pressure resistance and AISI 316L for required chemical resistance (dual rated)
- 2) Weight incl. pipe, housing weight, see Page 32

## JIS flanges, connection dimensions as per JIS B 2220, raised face RF

Version	Flange							Screwholes			Flange weight <sup>2</sup> [kg]
	Material <sup>1</sup>	Nominal diameter	Nominal pressure	Diameter	Thickness	Raised face diameter	Raised face height	Quantity	Diameter	Hole circle	
				D [mm]	b [mm]	g [mm]	f [mm]		g <sub>2</sub> [mm]	k [mm]	
7B	AISI 316L	40 A	10 K	144	16	81	2	4	19	105	1.8
7C	AISI 316L	50 A	10 K	155	16	96	2	4	19	120	2.2
7D	AISI 316L	80 A	10 K	185	18	127	2	8	19	150	3.5
7L	AISI 316L	100 A	10 K	210	18	151	2	8	19	175	4.6

1) AISI 316L/1.4435

2) Weight incl. pipe, housing weight, see Page 32

## Installation height H, devices with a flange

	Cover	Aluminum housing [mm]	Polyester housing [mm]	Stainless steel housing [mm]
Without a flame barrier	Flat	201 + flange thickness b	201 + flange thickness b	189 + flange thickness b
	High (with sight glass) <sup>1</sup>	212 + flange thickness b	201 + flange thickness b	205 + flange thickness b
With a flame barrier	Flat	312 + flange thickness b	322 + flange thickness b	310 + flange thickness b
	High (with sight glass)	333 + flange thickness b	322 + flange thickness b	326 + flange thickness b

1) Devices with the FHB20 display and operating module are always supplied with a high cover or with a cover with a sight glass.



**Process connection DB50L and DB50S (food version)**

**Universal process adapter**

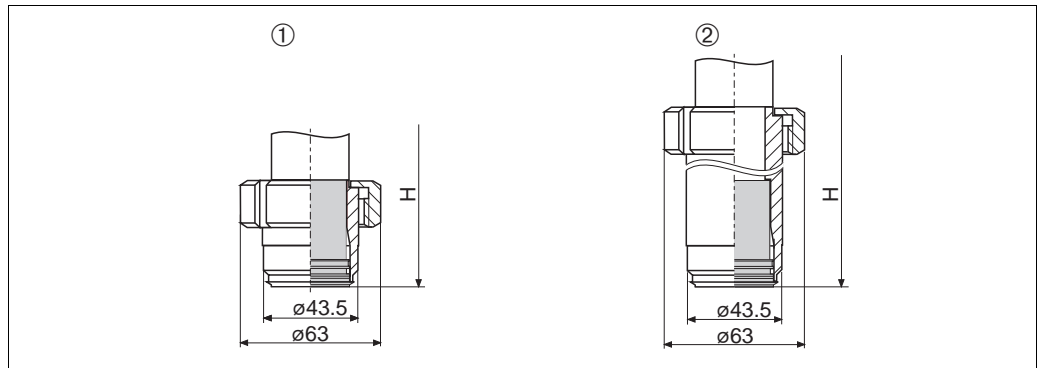

P01-DB5xxxx-06-xx-xx-xx-021

Process connection DB50L/DB50S, material: AISI 316L/1.4435;

Surface roughness of the surfaces in contact with the medium  $R_a \leq 0.8 \mu\text{m}$  as standard. Lower surface roughness on request.

1 Version 00: universal process adapter incl. silicone molded seal, 3A

2 Version 57: universal process adapter, extension 6 inch incl. silicone molded seal, 3A

**Installation height H, devices with universal process adapter**

	Cover	Aluminum housing [mm]	Polyester housing [mm]	Stainless steel housing [mm]
Universal process adapter	Flat	221	221	209
	High (with sight glass) <sup>1</sup>	232	221	225
Universal process adapter with 6 inch extension	Flat	318	318	306
	High (with sight glass)	329	318	322

1) Devices with the FHB20 display and operating module are always supplied with a high cover or with a cover with a sight glass.

**Tri-Clamp ISO 2852**

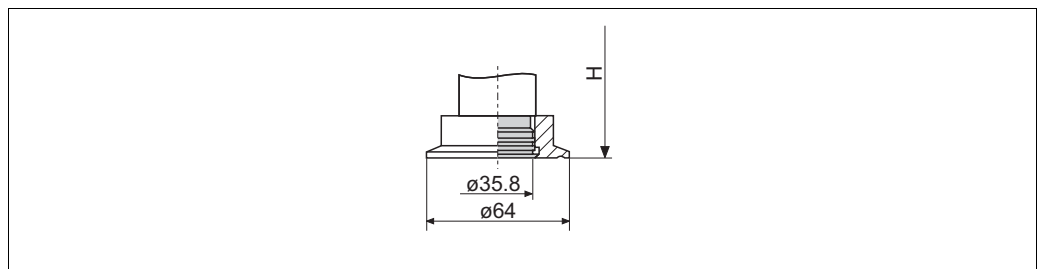

P01-DB5xxxx-06-xx-xx-xx-015

Process connection DB50L/DB50S, version 50: Tri-Clamp ISO 2852 DN 40 – DN 51 (2")/DIN 32676 DN 50, EHEDG, 3A; Material: AISI 316L/1.4435; surface roughness of surfaces in contact with the medium  $R_a \leq 0.8 \mu\text{m}$  as standard. Lower surface roughness on request.

Hygienic connections

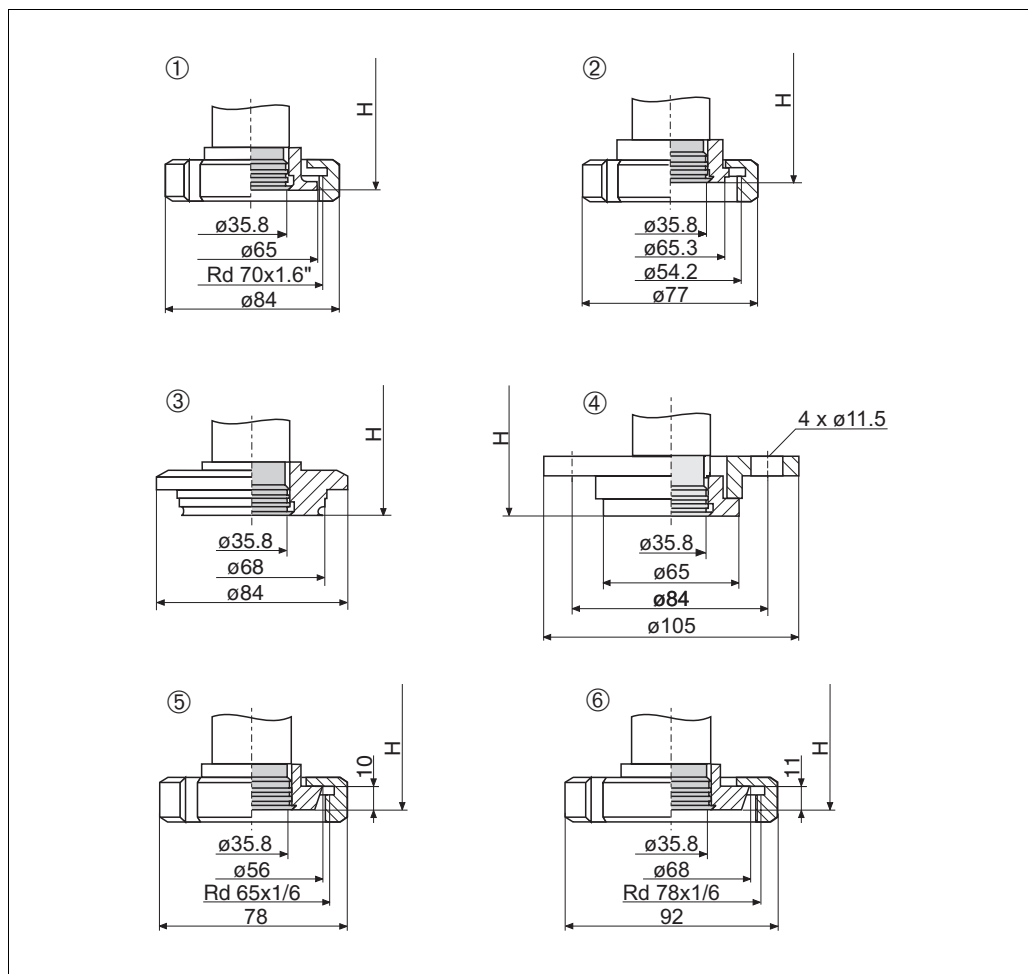

P01-DB5xxxx-06-xx-xx-xx-010

Hygienic connections DB50L: DIN 11851 with coupling nut, material: AISI 316L/1.4435, surface roughness of surfaces in contact with the medium  $R_a \leq 0.8 \mu\text{m}$  as standard. Lower surface roughness on request.

- 1 Version 53: SMS 2" PN 25, EHEDG, 3A
- 2 Version 56: ISO 2385 IDF 2", EHEDG, 3A
- 3 Version 55 : Varivent type N for pipes DN 40 – DN 162 PN 40, EHEDG
- 4 Version 44: DRD 65 mm PN 25, EHEDG, 3A
- 5 Version 40: DIN 11851 DN 40 PN 40
- 6 Version 41: DIN 11851 DN 50 PN 40

Installation height H, devices with universal process adapter, Tri-Clamp or hygienic connection

	Cover	Aluminum housing [mm]	Polyester housing [mm]	Stainless steel housing [mm]
Without a flame barrier	Flat	221	221	209
	High (with sight glass) <sup>1</sup>	232	221	225

1) Devices with the FHB20 display and operating module are always supplied with a high cover or with a cover with a sight glass.

Process connections DB51 and DB51A (rod/pipe version) Threaded connection ISO 228 and NPT

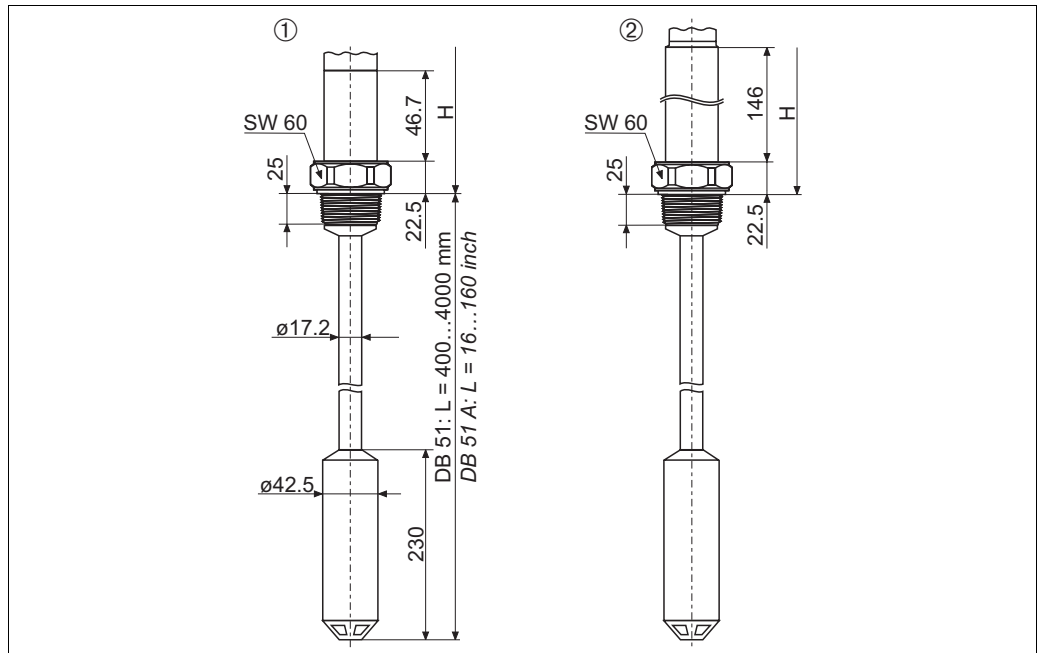

P01-DB5xxxx-06-xx-xx-xx-026

DB51(A), rod version with thread

- 1 DB51(A), thread G 1 1/2 or 1 1/2 NPT without flame barrier
- 2 DB51 (A), thread G 1 1/2 or 1 1/2 NPT with flame barrier  
(flame barrier for use in hazardous areas, Zone 0)
- H For installation height H, see Page 22

EN/DIN, ANSI and JIS flanges

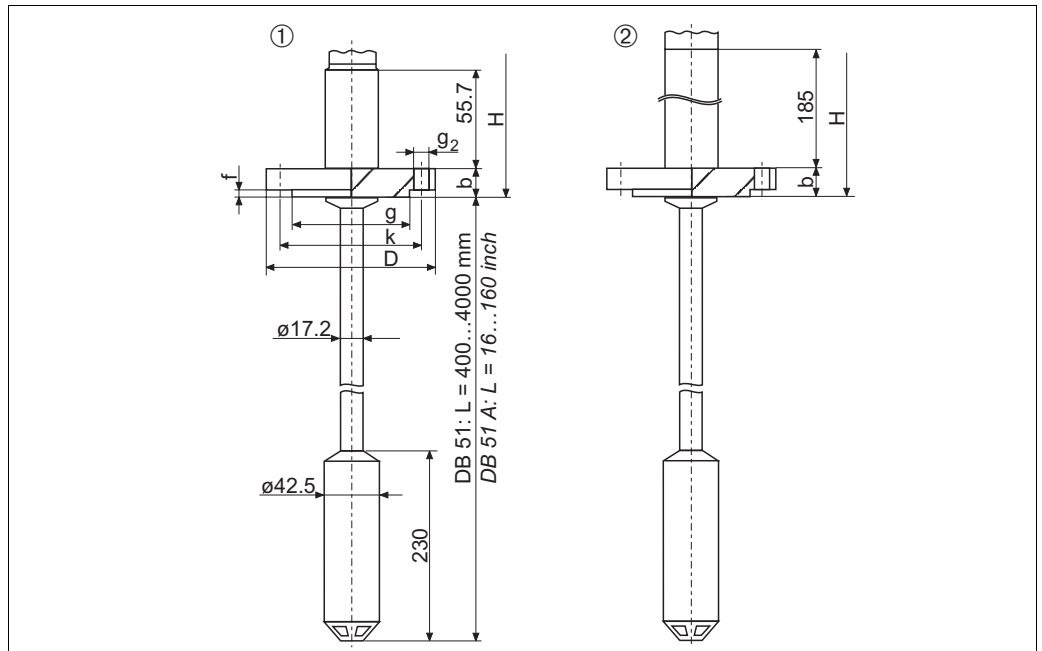

P01-DB5xxxx-06-xx-xx-xx-027

DB51(A), rod version with flange

- 1 DB51(A), flange without flame barrier
- 2 DB51(A), flange with flame barrier  
(flame barrier for use in hazardous areas, Zone 0)
- H For installation height H, see Page 24
- For process connection dimensions, see Page 23 ff.

Dimensions of Deltapilot S  
DB52 and DB52A (cable  
version)

Threaded connection ISO 228 and NPT

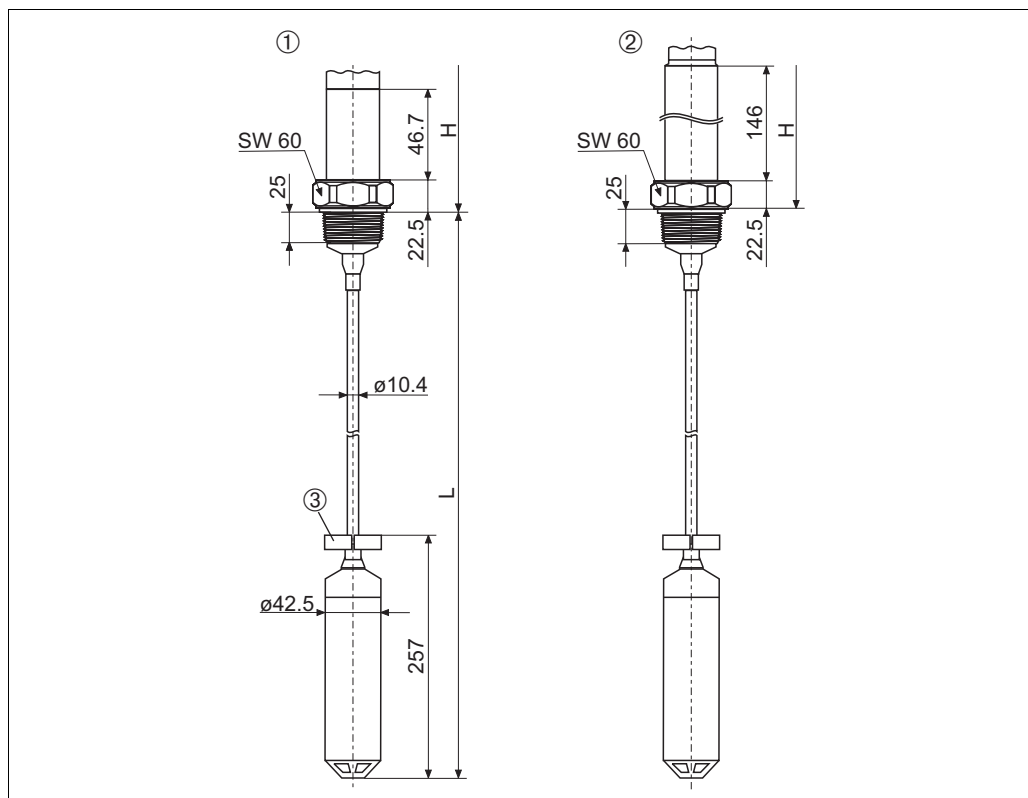

P01-DB5xxxxx-06-xx-xx-xx-028

*DB52(A), cable version with thread*

- 1 *DB52(A), thread G 1 1/2 and 1 1/2 NPT without flame barrier*
- 2 *DB52(A), thread G 1 1/2 and 1 1/2 NPT with flame barrier  
(flame barrier for use in hazardous areas, Zone 0)*
- 3 *Clamp for clamping fixture*
- H *For installation height H, see Page 22*
- L *Probe length:  
Without approval, EEx nA II T6: 0.5 to 200 m (20 to 7874 inch)  
EEx ia IIC T6, FM IS, CSA IS: 0.5 to 100 m (20 to 3937 inch)*

EN/DIN, ANSI and JIS flanges

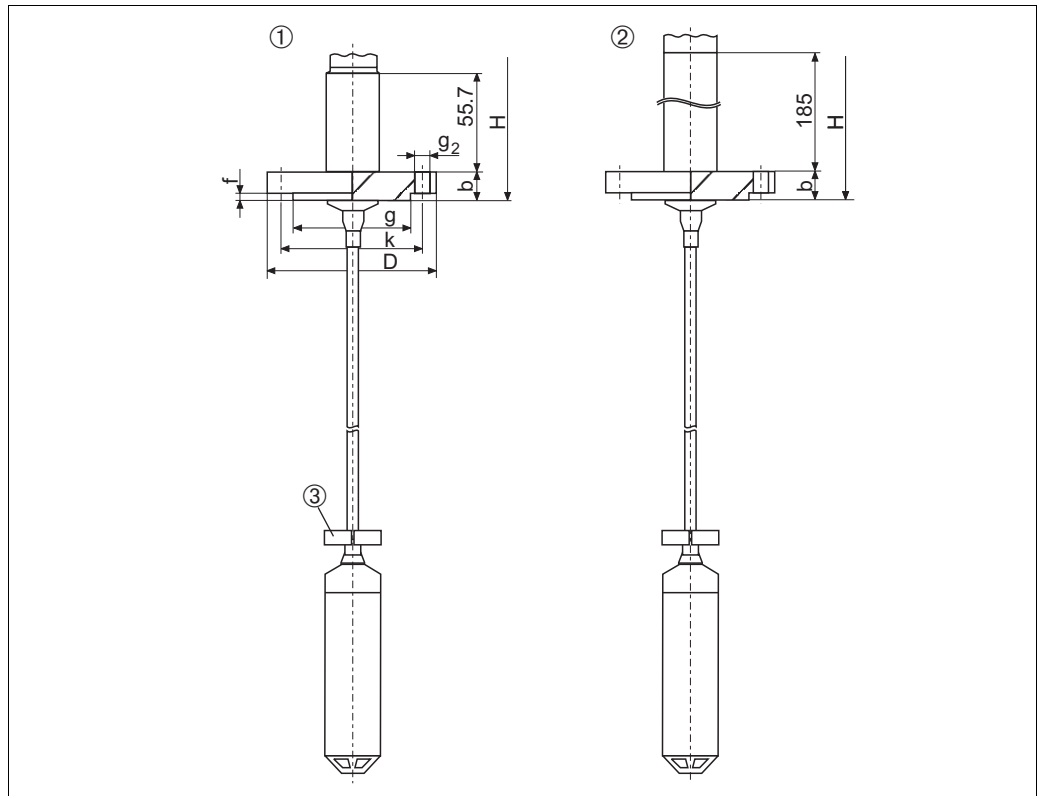

P01-DB5xxxx-06-xx-xx-xx-029

DB52(A), cable version with flange

- 1 DB52(A), flange without flame barrier
  - 2 DB52(A), flange with flame barrier  
(flame barrier for use in hazardous areas, Zone 0)
  - 3 Clamp for clamping fixture
  - H For installation height H, see Page 24
  - L Probe length:  
Without approval, EEx nA II T6: 0.5 to 200 m (20 to 7874 inch)  
EEx ia IIC T6, FM IS, CSA IS: 0.5 to 100 m (20 to 3937 inch)
- For process connection dimensions, see Page 23 ff.

### Dimensions of Deltapilot S DB53 and DB53A (suspension clamp and mounting bracket)

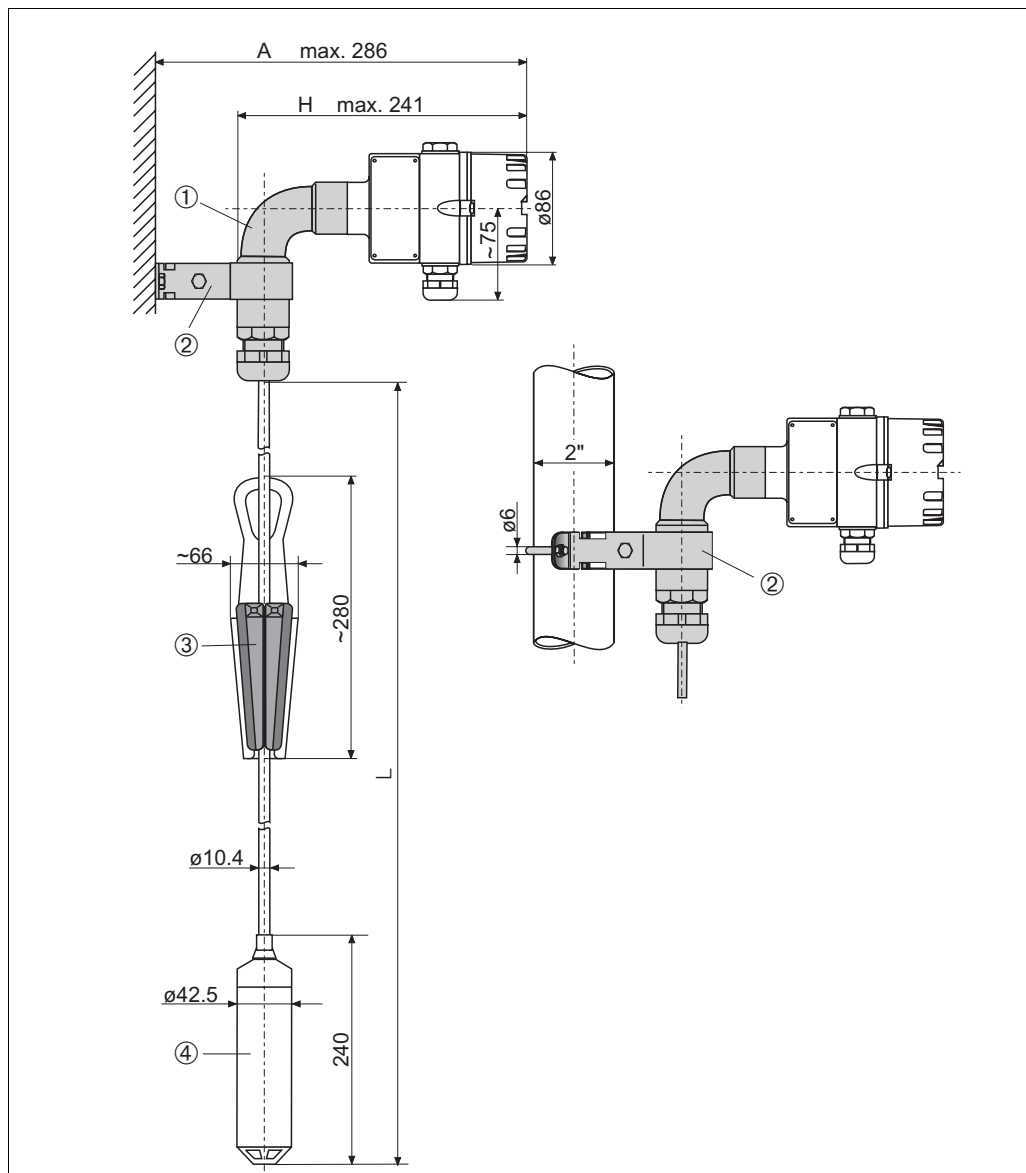

P01-DB5xxxxx-06-xx-xx-xx-007

DB53 with suspension clamp and mounting bracket

- 1 Pipe bend
- 2 Mounting bracket for pipe and wall mounting
- 3 Suspension clamp
- 4 Measuring cell tube
- L Probe length:  
Without approval, EEx nA II T6: 0.5 to 200 m (20 to 7874 inch)  
EEx ia IIC T6, FM IS, CSA IS: 0.5 to 100 m (20 to 3937 inch)

#### Dimension A

Cover	Aluminum housing	Polyester housing	Stainless steel housing
Flat	265 mm	273 mm	264 mm
High (with sight glass)	286 mm	273 mm	280 mm

#### Dimension H

Cover	Aluminum housing	Polyester housing	Stainless steel housing
Flat	219 mm	227 mm	218 mm
High (with sight glass)	240 mm	227 mm	234 mm

**Dimensions of connecting cable with housing adapter and mounting bracket**

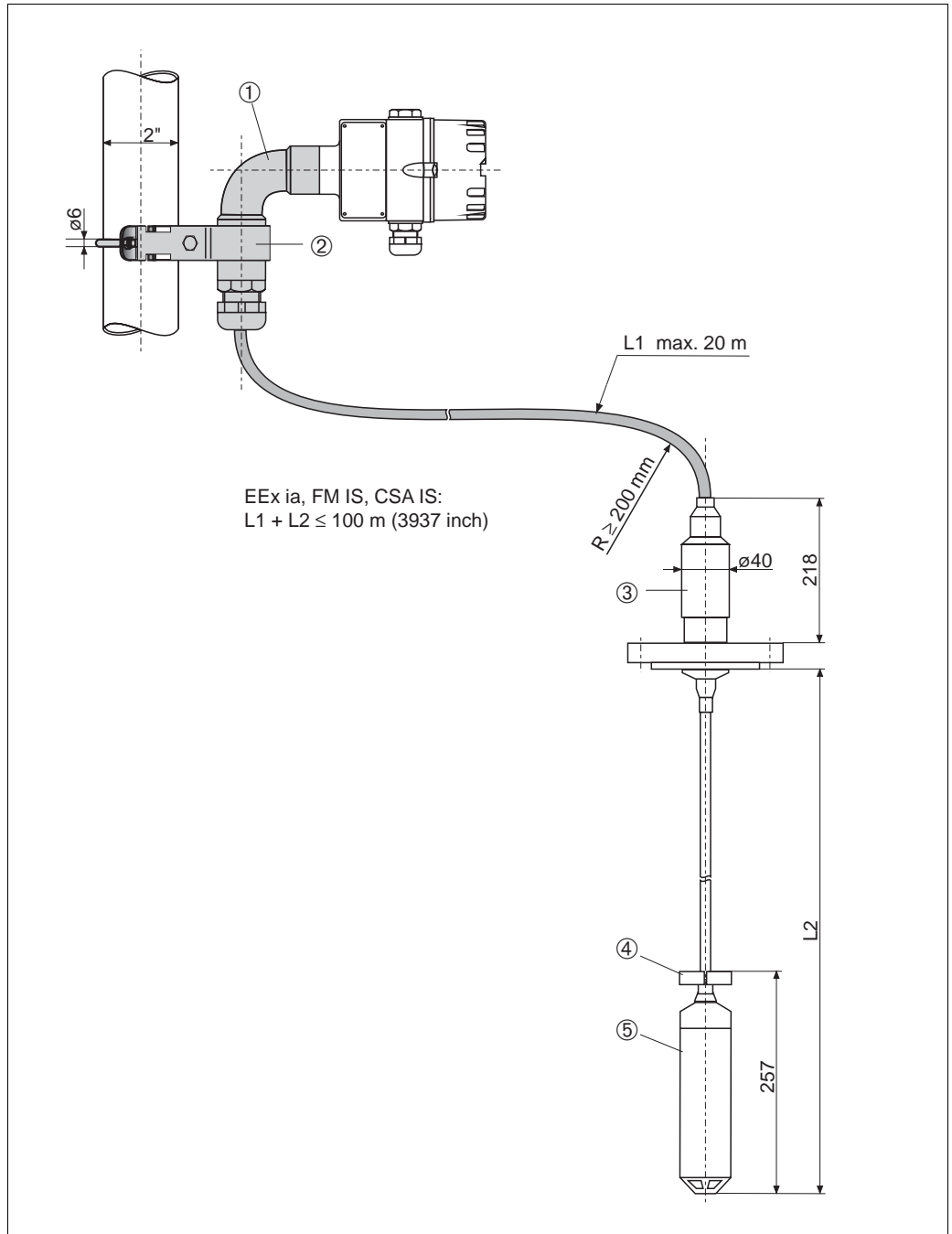

Connecting cable with housing adapter and mounting bracket, here shown with a DB52

- 1 Pipe bend
- 2 Mounting bracket for pipe and wall mounting
- 3 Housing adapter
- 4 Clamp for clamping fixture
- 5 Measuring cell tube
- L Probe length

Note!

- For DB50, DB50L, DB51, DB52, order the housing adapter and the mounting bracket via feature 90 "Additional option" or subsequently as an accessory. → See also Page 19 and Page 56, "Housing adapter with mounting bracket" section.
- When using a housing adapter in the EEx ia, FM IS or CSA IS area, the total cable length (connecting cable (L1) + extension cable (L2)) must not exceed 100 m.

**Weight****Housing**

	<b>Aluminum housing</b>	<b>Polyester housing</b>	<b>Stainless steel housing</b>
With flat cover, incl. electronic insert	0.8 kg	0.7 kg	0.9 kg
With high cover, incl. electronic insert	1.15 kg	0.7 kg	1.0 kg

**Process connection DB50(A)**

<b>Process connection incl. sensor</b>	<b>Weight</b>
Threaded connection without a flame barrier incl. sensor	0.8 kg
Threaded connection with a flame barrier incl. sensor	1.35 kg
Flange connection without a flame barrier incl. sensor, without a flange	0.45 kg
Flange connection with a flame barrier incl. sensor, without a flange	1.0 kg

Note!

- Total weight of device with threaded connection = weight of housing + weight of process connection DB50(A)
- Total weight of device with flange connection = weight of housing + weight of process connection DB50(A) + weight of flange (→ see Page 23 ff)

**Deltapilot process connections DB50L and DB50S (food version)**

<b>Process connection incl. sensor</b>	<b>Weight</b>
Tri-Clamp ISO 2852 DN 40 – DN 51 (2")/DIN 32676 DN 50	0.6 kg
SMS 2" incl. nut	0.95 kg
ISO 2385 IDF 2" incl. nut	1.0 kg
Varivent type N for pipes DN 40 – DN 162	0.9 kg
DRD 65 mm	1.05 kg
DIN 11851 dairy fitting DN 40 incl. nut	0.8 kg
DIN 11851 dairy fitting DN 50 incl. nut	1.1 kg
Universal process adapter	0.7 kg
Universal process adapter with 6 inch extended diaphragm seal	1.5 kg

Note!

- Total weight of device = weight of housing + weight of process connection DB50L and DB50S



**Process connection and pipe DB51(A)**

Process connection incl. sensor	Weight
Pipe incl. cable	0.77 kg/m
Threaded connection without a flame barrier incl. measuring cell tube and sensor	1.65 kg
Threaded connection with a flame barrier incl. measuring cell tube and sensor	2.2 kg
Flange connection without a flame barrier incl. measuring cell tube and sensor, without a flange	1.3 kg
Flange connection with a flame barrier incl. measuring cell tube and sensor, without a flange	1.85 kg

Note!

- Total weight of device with threaded connection = weight of housing + weight of pipe incl. cable x length + weight of process connection DB51(A)
- Total weight of device with flange connection = weight of housing + weight of pipe incl. cable x length + weight of process connection DB51(A)+ weight of flange (→ see Page 23 ff)

**Process connection and cable DB52(A)**

Process connection incl. sensor	Weight
PE cable	0.13 kg/m
FEP cable	0.18 kg/m
Threaded connection without a flame barrier incl. measuring cell tube and sensor	1.65 kg
Threaded connection with a flame barrier incl. measuring cell tube and sensor	2.2 kg
Flange connection without a flame barrier incl. measuring cell tube and sensor, without a flange	1.3 kg
Flange connection with a flame barrier incl. measuring cell tube and sensor, without a flange	1.85 kg

Note!

- Total weight of device with threaded connection = weight of housing + weight of cable x length + weight of process connection DB52(A)
- Total weight of device with flange connection = weight of housing + weight of cable x length + weight of process connection DB52(A)+ weight of flange (→ see Page 23 ff)

**Process connection DB53 (A) – securing with suspension clamp and mounting bracket**

Process connection incl. sensor	Weight
PE cable	0.13 kg/m
FEP cable	0.18 kg/m
Mounting bracket	0.2 kg
Pipe bend incl. cable entry	0.65 kg
Suspension clamp	0.4 kg
Measuring cell tube incl. sensor	1.0 kg

Note!

- Total weight of device = weight of housing + weight of cable x length + weight of mounting bracket + weight of pipe bend + weight of suspension clamp + weight of measuring cell tube

**Weight of additional options**

Accessories	Weight
Mounting bracket	0.2 kg
Pipe bend incl. cable entry	0.65 kg
Housing adapter for DB51(A) and DB 52(A)	0.85 kg
Housing adapter for DB50(A) and DB50L/S	0.7 kg

**Material****Housing**

	Aluminum housing	Polyester housing	Stainless steel housing
Housing	EN AC-44300 (GD-AISI12) with synthetic coating, blue/gray	Fiberglass reinforced polyester, blue/gray (PBT-GF)	AISI 316L (1.4404)
Flat cover	EN AC-44300 with synthetic coating, gray	Fiberglass reinforced polyester, gray (PBT-GF)	AISI 316L (1.4404)
High cover with sight glass	EN AC-44300 with synthetic coating, gray	Polycarbonate (PC)	AISI 316L (1.4404)
Sight glass	Glass	Polycarbonate (PC)	Glass
Seal for housing cover	EPDM O-ring	Silicone O-ring (VQM)	Silicone molded seal (VQM)

- Electronic insert: plastic ABS housing, cast electronic insert
- Process connections: AISI 316L (1.4435) or Alloy C4 (2.4610)
- Process diaphragm: Alloy C276 (2.4819)
- Measuring cell: AISI 316L (1.4435) or C276 (2.4819)
- Probe tube DB51(A): AISI 316L (1.4435) or Alloy C4 (2.4610)
- Extension cable DB52(A) and DB53(A): multi-core cable with steel wire braiding, FEP or PE insulation
- Measuring cell tube DB51(A), DB52(A) and DB53(A): AISI 316L (1.4435) or Alloy C4 (2.4610)/C22 (2.4602)
- Suspension clamp: AISI 316L (1.4404) and fiberglass reinforced polyamide (PA)
- Seals
  - For measuring cell sealing, see Ordering information, Page 36
  - Universal process adapter: silicone profile packing, suitable for foodstuffs in accordance with BGA XV FDA 21 CRF 177.2600
  - Process connection DRD: PTFE seal
- Protection cap for diaphragm DB51, DB52, DB53: PFA (perfluoralkoxy) plastic
- Clamp for clamping fixture for DB52(A): PFA (perfluoralkoxy) plastic, AISI 304 (1.4301)
- Housing adapter and pipe bend:
  - Housing adapter: AISI 316L (1.4435) and AISI 316 Ti (1.4571)
  - Multi-core cable with steel braiding, PE insulation
  - Pipe bend:
    - AISI 316 Ti (1.4571) and AISI 321 (1.4541)
    - Cable gland:
      - CuZn nickel-plated
      - O-ring: NBR
      - Sealing insert: TPE-V
      - O-ring: EPDM
- Mounting bracket: AISI 304 (1.4301)

## Certificates and approvals

---

<b>CE mark</b>	The device meets the legal requirements of the EC directives. Endress+Hauser confirms that the device has been successfully tested by applying the CE mark.
<b>Ex approvals</b>	All explosion protection data are given in separate documentation which is available upon request. The Ex documentation is supplied as standard with all devices approved for use in explosion hazardous areas. → See also Page 59 ff, "Safety Instructions" and "Installation/Control Drawings" sections.
<b>Overfill protection</b>	WHG (German Water Resources Act)
<b>Seismic test</b>	DB53 with FEB22 electronic insert passed in accordance with IEEE 344-1987.
<b>Marine approval</b>	DB50, DB50L, DB52 and DB53 with FEB17 electronic insert: German Lloyd, certificate No.: 99350 - 97 HH
<b>Standards and guidelines</b>	DIN EN 60770 (IEC 60770): Transmitters for controlling in systems used in industrial process technology Part 1: Methods for evaluating the operating behavior  DIN 16086: Electrical pressure measuring devices, pressure sensors, transmitters, pressure measuring devices Terms, specifications in data sheets  EN 61326: Electrical equipment for control technology and laboratory application – EMC requirements

## Ordering information

### DB50 – compact version

<b>10</b>	<b>Approval:</b>		
	A	Version for non-hazardous area	
	E	Version for non-hazardous area, overfill protection WHG	
	G	ATEX II 1/2 G EEx ia IIC T6	
	C	ATEX II 1/2 G EEx ia IIC T6, flame barrier	
	D	ATEX II 1/2 G EEx ia IIC T6, overfill protection WHG	
	B	ATEX II 1/2 G EEx ia IIC T6, flame barrier, overfill protection WHG	
	N	ATEX II 3 G EEx nA II T6	
	S	CSA IS, Class I, Division 1, Groups A – D	
	T	CSA IS, Class I, Division 2, Groups A – D	
<b>20</b>	<b>Probe:</b>		
	B	Compact version + inspection certificate as per EN 10204–3.1 material (AISI 316L wetted)	
	C	Compact version	
<b>30</b>	<b>Process connection:</b>		
		<b>Threaded connections</b>	
	10	ISO 228 G 1 1/2, AISI 316L	
	11	ISO 228 G 1 1/2, Alloy C	
	12	ANSI 1 1/2 NPT, AISI 316L	
		<b>EN flanges</b>	
	20	DN 40 PN 10/16 B1, AISI 316L	
	21	DN 50 PN 10/16 B1, AISI 316L	
	22	DN 80 PN 10/16 B1, AISI 316L	
	23	DN 100 PN 10/16 B1, AISI 316L	
		<b>ANSI flanges</b>	
	30	1 1/2" 150 lbs RF, AISI 316/316L	
	31	2" 150 lbs RF, AISI 316/316L	
	32	3" 150 lbs RF, AISI 316/316L	
	33	4" 150 lbs RF, AISI 316/316L	
		<b>JIS flanges</b>	
	7B	10K 40A RF, AISI 316L	
	7C	10K 50A RF, AISI 316L	
	7D	10K 80A RF, AISI 316L	
	7L	10K 100A RF, AISI 316L	
<b>40</b>	<b>Measuring range:</b>		
	BA	0 to 100 mbar/1 mH <sub>2</sub> O/40 inH <sub>2</sub> O	
	BB	0 to 400 mbar/4 mH <sub>2</sub> O/160 inH <sub>2</sub> O	
	BC	0 to 1200 mbar/12 mH <sub>2</sub> O/480 inH <sub>2</sub> O	
	BD	0 to 4000 mbar/40 mH <sub>2</sub> O/1600 inH <sub>2</sub> O	
	BE	0 to 10 bar/100 mH <sub>2</sub> O/4000 inH <sub>2</sub> O	
	DA	–100 to 100 mbar/1 mH <sub>2</sub> O/40 inH <sub>2</sub> O	
	DB	–400 to 400 mbar/4 mH <sub>2</sub> O/160 inH <sub>2</sub> O	
	DC	–900 to 1200 mbar/12 mH <sub>2</sub> O/480 inH <sub>2</sub> O	
	DD	–900 to 4000 mbar/40 mH <sub>2</sub> O/1600 inH <sub>2</sub> O	
	DE	–0.9 to 10 bar/100 mH <sub>2</sub> O/4000 inH <sub>2</sub> O	
<b>50</b>	<b>Linearity; Fill fluid:</b>		
	1	< 0.2 % of measuring range; FDA compliant	
	2	< 0.2 % of measuring range; inert oil	
	3	< 0.1 % of measuring range; FDA compliant	
	4	< 0.1 % of measuring range; inert oil	
	Z	Additional specification	
<b>60</b>	<b>Measuring sensor seal:</b>		
	1	Viton	
	2	EPDM	
	5	Kalrez	
	3	Sensor welded	
DB50			Order code

→For continuation of ordering information for DB50, see the following page.



**DB50L – compact version for hygienic applications**



Only in conjunction with an approved process connection

10	<b>Approval:</b>		
	A	Version for non-hazardous area	
	E	Version for non-hazardous area, overflow protection WHG	
	G	ATEX II 1/2 G EEx ia IIC T6	
	D	ATEX II 1/2 G EEx ia IIC T6, overflow protection WHG	
	N	ATEX II 3 G EEx nA II T6	
	S	CSA IS, Class I, Division 1, Groups A – D	
	T	CSA IS, Class I, Division 2, Groups A – D	
20	<b>Probe:</b>		
	B	Compact version + inspection certificate as per EN 10204-3.1 material (AISI 316L wetted)	
	C	Compact version	
30	<b>Process connection:</b>		
		<b>Tri-Clamp connections</b>	
	50	ISO 2852 DN 40 – 51 (2"), DIN 32676 DN 50, AISI 316L, EHEDG, 3A	
		<b>Hygienic connections</b>	
	53	SMS 2" PN 25, AISI 316L, EHEDG, 3A	
	56	IDF 2" ISO 2853, AISI 316L, EHEDG, 3A	
	55	Varivent type N for pipes DN 40 – DN 162, PN 40, AISI 316L, EHEDG	
	44	DRD 65 mm, PN 25, AISI 316L, EHEDG, 3A	
	00	Universal process adapter 44 mm incl. silicone molded seal, 3A	
	57	Universal process adapter 44 mm, extension 6" incl. silicone molded seal, 3A	
	40	DIN 11851 DN 40 PN 40, AISI 316L	
41	DIN 11851 DN 50 PN 40, AISI 316L		
40	<b>Measuring range:</b>		
	BA	0 to 100 mbar/1 mH <sub>2</sub> O/40 inH <sub>2</sub> O	
	BB	0 to 400 mbar/4 mH <sub>2</sub> O/160 inH <sub>2</sub> O	
	BC	0 to 1200 mbar/12 mH <sub>2</sub> O/480 inH <sub>2</sub> O	
	BD	0 to 4000 mbar/40 mH <sub>2</sub> O/1600 inH <sub>2</sub> O	
	BE	0 to 10 bar/100 mH <sub>2</sub> O/4000 inH <sub>2</sub> O	
	DA	-100 to 100 mbar/1 mH <sub>2</sub> O/40 inH <sub>2</sub> O	
	DB	-400 to 400 mbar/4 mH <sub>2</sub> O/160 inH <sub>2</sub> O	
	DC	-900 to 1200 mbar/12 mH <sub>2</sub> O/480 inH <sub>2</sub> O	
	DD	-900 to 4000 mbar/40 mH <sub>2</sub> O/1600 inH <sub>2</sub> O	
DE	-0.9 to 10 bar/100 mH <sub>2</sub> O/4000 inH <sub>2</sub> O		
50	<b>Linearity; Fill fluid:</b>		
	1	< 0.2 % of measuring range; FDA compliant	
	3	< 0.1 % of measuring range; FDA compliant	
60	<b>Measuring sensor seal:</b>		
	5	Kalrez	
	4	Viton (only with universal process adapter)	
	3	Sensor welded	
DB50L			Order code

→For continuation of ordering information for DB50L, see the following page.

**DB50L – compact version for hygienic applications (continued)**

<b>70</b>	<b>Electronics; Output:</b>
	<p><b>Electronic inserts without integrated overvoltage protection</b></p> <p>A Without integrated electronic insert (e.g. for ordering spare parts)</p> <p>B FEB11, 3-wire analog signal</p> <p>C FEB17, 2-wire PFM signal</p> <p>E FEB22, 4 to 20 mA HART</p> <p>G FEB22, 4 to 20 mA HART, with FHB20 onsite display</p> <p>H FEB24, PROFIBUS PA</p> <p>K FEB24, PROFIBUS PA, with FHB20 onsite display</p> <p>I FEB26, FOUNDATION Fieldbus</p> <p>2 FEB26, FOUNDATION Fieldbus, with FHB20 onsite display</p> <p><b>Electronic inserts with integrated overvoltage protection</b></p> <p>M FEB11P, 3-wire analog signal</p> <p>N FEB17P, 2-wire PFM signal</p> <p>R FEB22P, 4 to 20 mA HART</p> <p>T FEB22P, 4 to 20 mA HART, with FHB20 onsite display</p> <p>U FEB24P, PROFIBUS PA</p> <p>W FEB24P, PROFIBUS PA, with FHB20 onsite display</p>
<b>80</b>	<b>Housing; Cable entry:</b>
	<p>A0 Without housing (e.g. for ordering spare parts)</p> <p>G1 Polyester housing, IP 66, gland M 20x1.5</p> <p>G2 Aluminum housing, IP 66, gland M 20x1.5</p> <p>G3 AISI 316L housing, IP 66, gland M 20x1.5</p> <p>P2 Aluminum housing, IP 66, plug M 12x1</p> <p>P3 AISI 316L housing, IP 66, plug M 12x1</p> <p>T2 Aluminum housing, IP 66, plug 7/8"</p> <p>T3 AISI 316L housing, IP 66, plug 7/8"</p> <p>E1 Polyester housing, NEMA 4X, thread 1/2 NPT</p> <p>E2 Aluminum housing, NEMA 4X, thread 1/2 NPT</p> <p>E3 AISI 316L housing, NEMA 4X, thread 1/2 NPT</p> <p>F1 Polyester housing, IP 66, thread G 1/2 A</p> <p>F2 Aluminum housing, IP 66, thread G 1/2 A</p> <p>F3 AISI 316L housing, IP 66, thread G 1/2 A</p>
<b>90</b>	<b>Additional option:</b>
	<p>0 Basic version</p> <p>1 5000 mm connecting cable with housing adapter, IP 68, separate electronics</p> <p>3 ... mm connecting cable with housing adapter, IP 68, separate electronics, max. 20000 mm</p> <p>A Basic version, adjusted measuring range</p> <p>3 5000 mm connecting cable with housing adapter, IP 68, separate electronics, adjusted measuring range</p>
DB50L	Complete order code

## DB51 – rod version

<b>10</b>	<b>Certificates:</b>		
	A	Version for non-hazardous area	
	E	Version for non-hazardous area, overfill protection WHG	
	G	ATEX II 1/2 G EEx ia IIC T6	
	C	ATEX II 1/2 G EEx ia IIC T6, flame barrier	
	D	ATEX II 1/2 G EEx ia IIC T6, overfill protection WHG	
	B	ATEX II 1/2 G EEx ia IIC T6, flame barrier, overfill protection WHG	
	N	ATEX II 3 G EEx nA II T6	
	S	CSA IS, Class I, Division 1, Groups A – D	
	T	CSA IS, Class I, Division 2, Groups A – D	
<b>20</b>	<b>Probe:</b>		
		Probe length 400 to 4000 mm	
	E	... mm probe tube made of AISI 316L	
	F	... mm probe tube made of Alloy C	
<b>30</b>	<b>Process connection:</b>		
		<b>Threaded connection</b>	
	10	ISO 228 G 1 1/2, AISI 316L	
	11	ISO 228 G 1/2, Alloy C	
	12	ANSI 1 1/2 NPT, AISI 316L	
		<b>EN flanges</b>	
	20	DN 40 PN 10/16 B1, AISI 316L	
	21	DN 50 PN 10/16 B1, AISI 316L	
	22	DN 80 PN 10/16 B1, AISI 316L	
	23	DN 100 PN 10/16 B1, AISI 316L	
		<b>ANSI flanges</b>	
	30	1 1/2" 150 lbs RF, AISI 316/316L	
	31	2" 150 lbs RF, AISI 316/316L	
	32	3" 150 lbs RF, AISI 316/316L	
	33	4" 150 lbs RF, AISI 316/316L	
		<b>JIS flanges</b>	
	7B	10K 40A RF, AISI 316L	
	7C	10K 50A RF, AISI 316L	
	7D	10K 80A, RF, AISI 316L	
	7L	10K 100A RF, AISI 316L	
<b>40</b>	<b>Measuring range:</b>		
	BA	0 to 100 mbar/1 mH <sub>2</sub> O/40 inH <sub>2</sub> O	
	BB	0 to 400 mbar/4 mH <sub>2</sub> O/160 inH <sub>2</sub> O	
	BC	0 to 1200 mbar/12 mH <sub>2</sub> O/480 inH <sub>2</sub> O	
	BD	0 to 4000 mbar/40 mH <sub>2</sub> O/1600 inH <sub>2</sub> O	
	BE	0 to 10 bar/100 mH <sub>2</sub> O/4000 inH <sub>2</sub> O	
	DA	-100 to 100 mbar/1 mH <sub>2</sub> O/40 inH <sub>2</sub> O	
	DB	-400 to 400 mbar/4 mH <sub>2</sub> O/160 inH <sub>2</sub> O	
	DC	-900 to 1200 mbar/12 mH <sub>2</sub> O/480 inH <sub>2</sub> O	
	DD	-900 to 4000 bar/40 mH <sub>2</sub> O/1600 inH <sub>2</sub> O	
	DE	-0.9 to 10 bar/100 mH <sub>2</sub> O/4000 inH <sub>2</sub> O	
<b>50</b>	<b>Linearity; Fill fluid:</b>		
	1	< 0.2 % of measuring range; FDA compliant	
	2	< 0.2 % of measuring range; inert oil	
	3	< 0.1 % of measuring range; FDA compliant	
	4	< 0.1 % of measuring range; inert oil	
	Z	Additional specification	
<b>60</b>	<b>Measuring sensor seal:</b>		
	1	Viton	
	2	EPDM	
	5	Kalrez	
	3	Welded	
DB51			Order code

→For continuation of ordering information for DB51, see the following page.







**DB52 – cable version with process connection (continued)**

70							<b>Electronics; Output:</b>	
							<b>Electronic inserts without integrated overvoltage protection</b>	
							A	Without integrated electronic insert (e.g. for ordering spare parts)
							B	FEB11, 3-wire analog signal
							C	FEB17, 2-wire PFM signal
							E	FEB22, 4 to 20 mA HART
							G	FEB22, 4 to 20 mA HART, with FHB20 onsite display
							H	FEB24, PROFIBUS PA
							K	FEB24, PROFIBUS PA, with FHB20 onsite display
							I	FEB26, FOUNDATION Fieldbus
							2	FEB26, FOUNDATION Fieldbus, with FHB20 onsite display
							<b>Electronic inserts with integrated overvoltage protection</b>	
							M	FEB11P, 3-wire analog signal
							N	FEB17P, 2-wire PFM signal
							R	FEB22P, 4 to 20 mA HART
							T	FEB22P, 4 to 20 mA HART, with FHB20 onsite display
							U	FEB24P, PROFIBUS PA
							W	FEB24P, PROFIBUS PA, with FHB20 onsite display
80							<b>Housing; Cable entry:</b>	
							A0	Without housing (e.g. for ordering spare parts)
							G1	Polyester housing IP 66, gland M 20x1.5
							G2	Aluminum housing IP 66, gland M 20x1.5
							G3	Stainless steel housing AISI 316L IP 66, gland M 20x1.5
							P2	Aluminum housing IP 66, plug M 12x1
							P3	Stainless steel housing AISI 316L IP 66, plug M 12x1
							T2	Aluminum housing IP 66, plug 7/8"
							T3	Stainless steel housing AISI 316L IP 66, plug 7/8"
							E1	Polyester housing NEMA 4X, thread 1/2 NPT
							E2	Aluminum housing NEMA 4X, thread 1/2 NPT
							E3	Stainless steel housing AISI 316L NEMA 4X, thread 1/2 NPT
							F1	Polyester housing IP 66, thread G 1/2 A
							F2	Aluminum housing IP 66, thread G 1/2 A
							F3	Stainless steel housing AISI 316L IP 66, thread G 1/2 A
90							<b>Additional option:</b>	
							0	Basic version
							1	5000 mm connecting cable with housing adapter, IP 68, separate electronics
							3	... mm connecting cable with housing adapter, IP 68, separate electronics, max. 20000 mm
							A	Basic version, adjusted measuring range
							C	5000 mm connecting cable with housing adapter, IP 68, separate electronics, adjusted measuring range
DB52							Complete order code	

## DB53 – cable version with suspension clamp

10	<b>Approval:</b>		
	A	Version for non-hazardous area	
	G	ATEX II 1/2 G EEx ia IIC T6	
	H	ATEX II 2 G EEx ia IIC T6	
	N	ATEX II 3 G EEx nA II T6	
	S	CSA IS, Class I, Division 1, Groups A – D	
T	CSA IS, Class I, Division 2, Groups A – D		
20	<b>Probe:</b>		
	K	... mm FEP extension cable (probe length: 0.5 to 200 m)	
	M	... mm PE extension cable (probe length: 0.5 to 200 m)	
	L	... mm FEP extension cable for EEx ia, CSA IS (probe length: 0.5 to 100 m)	
N	... mm PE extension cable for EEx ia, CSA IS (probe length: 0.5 to 100 m)		
30	<b>Process connection:</b>		
	70	Cable probe without suspension clamp	
71	Suspension clamp AISI 316L		
40	<b>Measuring range:</b>		
	BA	0 to 100 mbar/1 mH <sub>2</sub> O/40 inH <sub>2</sub> O	
	BB	0 to 400 mbar/4 mH <sub>2</sub> O/160 inH <sub>2</sub> O	
	BC	0 to 1200 mbar/12 mH <sub>2</sub> O/480 inH <sub>2</sub> O	
	BD	0 to 4000 mbar/40 mH <sub>2</sub> O/1600 inH <sub>2</sub> O	
BE	0 to 10 bar/100 mH <sub>2</sub> O/4000 inH <sub>2</sub> O		
50	<b>Linearity; Fill fluid:</b>		
	1	< 0.2 % of measuring range; FDA compliant	
	2	< 0.2 % of measuring range; inert oil	
	3	< 0.1 % of measuring range; FDA compliant	
	4	< 0.1 % of measuring range; inert oil	
Z	Additional specification		
60	<b>Measuring sensor seal:</b>		
	1	Viton	
	2	EPDM	
	5	Kalrez	
3	Sensor welded		
70	<b>Electronics; Output:</b>		
	<b>Electronic inserts without integrated overvoltage protection</b>		
	A	Without integrated electronic insert (e.g. for ordering spare parts)	
	B	FEB11, 3-wire analog signal	
	C	FEB17, 2-wire PFM signal	
	E	FEB22, 4 to 20 mA, HART	
	G	FEB22, 4 to 20 mA, HART, with FHB20 onsite display	
	H	FEB24, PROFIBUS PA	
	K	FEB24, PROFIBUS PA, with FHB20 onsite display	
	1	FEB26, FOUNDATION Fieldbus	
	2	FEB26, FOUNDATION Fieldbus, with FHB20 onsite display	
	<b>Electronic inserts with integrated overvoltage protection</b>		
	M	FEB11P, 3-wire analog signal	
	N	FEB17P, 2-wire PFM signal	
	R	FEB22P, 4 to 20 mA, HART	
T	FEB22P, 4 to 20 mA, HART, with FHB20 onsite display		
U	FEB24P, PROFIBUS PA		
W	FEB24P, PROFIBUS PA, with FHB20 onsite display		
DB53			Order code

→For continuation of ordering information for DB53, see the following page.

**DB53 – cable version with suspension clamp (continued)**

80										<b>Housing; Cable entry:</b>	
										A0	Without housing (e.g. for ordering spare parts)
										G1	Polyester housing IP 66, gland M 20x1.5
										G2	Aluminum housing IP 66, gland M 20x1.5
										G3	Stainless steel housing AISI 316L IP 66, gland M 20x1.5
										P2	Aluminum housing IP 66, plug M 12x1
										P3	Stainless steel housing AISI 316L IP 66, plug M 12x1
										T2	Aluminum housing IP 66, plug 7/8"
										T3	Stainless steel housing AISI 316L IP 66, plug 7/8"
										E1	Polyester housing NEMA 4X, thread 1/2 NPT
										E2	Aluminum housing NEMA 4X, thread 1/2 NPT
										E3	Stainless steel housing AISI 316L NEMA 4X, thread 1/2 NPT
										F1	Polyester housing IP 66, thread G 1/2 A
										F2	Aluminum housing IP 66, thread G 1/2 A
										F3	Stainless steel housing IP 66, thread G 1/2 A
90										<b>Additional option:</b>	
										0	Basic version
										A	Basic version, adjusted measuring range
DB53											Complete order code

## DB50A – compact version

<b>10</b>	<b>Approval:</b>			
	A	Version for non-hazardous area		
	N	ATEX II 3 G EEx nA II T6		
	O	FM IS, Class I, Division 1, 2, Groups A – D		
	S	CSA IS, Class I, Division 1, Groups A – D		
	T	CSA IS, Class I, Division 2, Groups A – D		
<b>20</b>	<b>Probe:</b>			
	C	Compact version		
<b>30</b>	<b>Process connection:</b>			
		<b>Threaded connection</b>		
	12	ANSI 1 1/2 NPT, AISI 316L		
		<b>ANSI flanges</b>		
	30	1 1/2" 150 lbs RF, AISI 316/316L		
	31	2" 150 lbs RF, AISI 316/316L		
	32	3" 150 lbs RF, AISI 316/316L		
	33	4" 150 lbs RF, AISI 316/316L		
		<b>JIS flange</b>		
	7C	JIS 10 K 50 A RF, AISI 316L		
<b>40</b>	<b>Measuring range:</b>			
	FA	0 to 1.5 psi/1 mH <sub>2</sub> O/40 inH <sub>2</sub> O		
	FB	0 to 6 psi/4 mH <sub>2</sub> O/160 inH <sub>2</sub> O		
	FC	0 to 15 psi/12 mH <sub>2</sub> O/480 inH <sub>2</sub> O		
	FD	0 to 60 psi/40 mH <sub>2</sub> O/1600 inH <sub>2</sub> O		
	FE	0 to 150 psi/100 mH <sub>2</sub> O/4000 inH <sub>2</sub> O		
	GA	-1.5 to 1.5 psi/1 mH <sub>2</sub> O/40 inH <sub>2</sub> O		
	GB	-6 to 6 psi/4 mH <sub>2</sub> O/160 inH <sub>2</sub> O		
	GC	-13 to 15 psi/12 mH <sub>2</sub> O/480 inH <sub>2</sub> O		
	GD	-13 to 60 psi/40 mH <sub>2</sub> O/1600 inH <sub>2</sub> O		
	GE	-13 to 150 psi/100 mH <sub>2</sub> O/4000 inH <sub>2</sub> O		
<b>50</b>	<b>Linearity; Fill fluid:</b>			
	1	< 0.2 % of measuring range; FDA compliant		
	2	< 0.2 % of measuring range; inert oil		
	3	< 0.1 % of measuring range; FDA compliant		
	4	< 0.1 % of measuring range; inert oil		
	Z	See additional specification		
<b>60</b>	<b>Measuring sensor seal:</b>			
	1	Viton		
	2	EPDM		
	5	Kalrez		
	3	Sensor welded		
<b>70</b>	<b>Electronics; Output:</b>			
		<b>Electronic inserts without integrated overvoltage protection</b>		
	A	Without integrated electronic insert (e.g. for ordering spare parts)		
	B	FEB11, 3-wire analog signal		
	C	FEB17, 2-wire PFM signal		
	E	FEB22, 4 to 20 mA, HART		
	G	FEB22, 4 to 20 mA, HART, with FHB20 onsite display		
	H	FEB24, PROFIBUS PA		
	K	FEB24, PROFIBUS PA, with FHB20 onsite display		
	1	FEB26, FOUNDATION Fieldbus		
	2	FEB26, FOUNDATION Fieldbus, with FHB20 onsite display		
		<b>Electronic inserts with integrated overvoltage protection</b>		
	M	FEB11P, 3-wire analog signal		
	N	FEB17P, 2-wire PFM signal		
	R	FEB22P, 4 to 20 mA, HART		
	T	FEB22P, 4 to 20 mA, HART, with FHB20 onsite display		
	U	FEB24P, PROFIBUS PA		
	W	FEB24P, PROFIBUS PA, with FHB20 onsite display		
DB50A				Order code

→For continuation of ordering information for DB50A, see the following page.

**DB50A – compact version  
(continued)**

80										<b>Housing; Cable entry:</b>	
										A0	Without housing (e.g. for ordering spare parts)
										G1	Polyester housing, IP 66, gland M 20x1.5
										G2	Aluminum housing, IP 66, gland M 20x1.5
										G3	AISI 316L housing, IP 66, gland M 20x1.5
										P2	Aluminum housing, IP 66, plug M 12x1
										P3	AISI 316L housing, IP 66, plug M 12x1
										T2	Aluminum housing, IP 66, plug 7/8"
										T3	AISI 316L housing, IP 66, plug 7/8"
										E1	Polyester housing, NEMA 4X, thread 1/2 NPT
										E2	Aluminum housing, NEMA 4X, thread 1/2 NPT
										E3	AISI 316L housing, NEMA 4X, thread 1/2 NPT
										F1	Polyester housing, IP 66, thread G 1/2 A
										F2	Aluminum housing, IP 66, thread G 1/2 A
										F3	AISI 316L housing, IP 66, thread G 1/2 A
90										<b>Additional option:</b>	
										0	Basic version
										5	200 inch connecting cable with housing adapter, NEMA 6P, separate electronics
										7	...inch connecting cable with housing adapter, NEMA 6P, separate electronics, max. 800 inch
										A	Basic version, adjusted measuring range
										D	200 inch connecting cable with housing adapter, NEMA 6P, separate electronics, adjusted measuring range
DB50A										Complete order code	

**DB50S – compact version for hygienic applications**

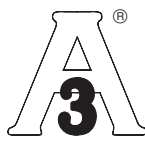

74 - 02

Only in conjunction with an approved process connection

<b>10</b>	<b>Approval:</b>		
	A	Version for non-hazardous area	
	N	ATEX II 3 G EEx nA II T6	
	O	FM IS, Class I, Division 1 and 2, Groups A – D	
	S	CSA IS, Class I, Division 1, Groups A – D	
	T	CSA IS, Class I, Division 2, Groups A – D	
<b>20</b>	<b>Probe:</b>		
	C	Compact version	
<b>30</b>	<b>Process connection:</b>		
	00	Universal process adapter 44 mm incl. silicone molded seal, 3A	
	57	Universal process adapter 44 mm, extension 6 inch, incl. silicone molded seal, 3A	
	50	Tri-Clamp ISO 2852 DN 40 – 51 (2") AISI 316L, EHEDG, 3A	
<b>40</b>	<b>Measuring range</b>		
	FA	0 to 1.5 psi/1 mH <sub>2</sub> O/40 inH <sub>2</sub> O	
	FB	0 to 6 psi/4 mH <sub>2</sub> O/160 inH <sub>2</sub> O	
	FC	0 to 15 psi/12 mH <sub>2</sub> O/480 inH <sub>2</sub> O	
	FD	0 to 60 psi/40 mH <sub>2</sub> O/1600 inH <sub>2</sub> O	
	FE	0 to 150 psi/100 mH <sub>2</sub> O/4000 inH <sub>2</sub> O	
	GA	–1.5 to 1.5 psi/1 mH <sub>2</sub> O/40 inH <sub>2</sub> O	
	GB	–6 to 6 psi/4 mH <sub>2</sub> O/160 inH <sub>2</sub> O	
	GC	–13 to 15 psi/12 mH <sub>2</sub> O/480 inH <sub>2</sub> O	
	GD	–13 to 60 psi/40 mH <sub>2</sub> O/1600 inH <sub>2</sub> O	
	GE	–13 to 150 psi/100 mH <sub>2</sub> O/4000 inH <sub>2</sub> O	
<b>50</b>	<b>Linearity; Fill fluid:</b>		
	1	< 0.2 % of measuring range; FDA compliant	
	3	< 0.1 % of measuring range; FDA compliant	
<b>60</b>	<b>Measuring sensor seal:</b>		
	5	Kalrez	
	4	Viton (only with universal process adapter)	
	3	Sensor welded	
<b>70</b>	<b>Electronics; Output:</b>		
	<b>Electronic inserts without integrated overvoltage protection</b>		
	A	Without integrated electronic insert (e.g. for ordering spare parts)	
	B	FEB11, 3-wire analog signal	
	C	FEB17, 2-wire PFM signal	
	E	FEB22, 4 to 20 mA, HART	
	G	FEB22, 4 to 20 mA, HART, with FHB20 onsite display	
	H	FEB24, PROFIBUS PA	
	K	FEB24, PROFIBUS PA, with FHB20 onsite display	
	1	FEB26, FOUNDATION Fieldbus	
	2	FEB26, FOUNDATION Fieldbus, with FHB20 onsite display	
	<b>Electronic inserts with integrated overvoltage protection</b>		
	M	FEB11P, 3-wire analog signal	
	N	FEB17P, 2-wire PFM signal	
	R	FEB22P, 4 to 20 mA, HART	
	T	FEB22P, 4 to 20 mA, HART, with FHB20 onsite display	
	U	FEB24P, PROFIBUS PA	
	W	FEB24P, PROFIBUS PA, with FHB20 onsite display	
DB50S			Order code

→For continuation of ordering information for DB50S, see the following page.



**DB50S – compact version for hygienic applications (continued)**

80										<b>Housing; Cable entry:</b>	
										A0	Without housing (e.g. for ordering spare parts)
										E1	Polyester housing NEMA 4X, thread 1/2 NPT
										E2	Aluminum housing NEMA 4X, thread 1/2 NPT
										E3	AISI 316L housing, NEMA 4X, thread 1/2 NPT
										P2	Aluminum housing, IP 66, plug M12x1
										P3	AISI 316L housing, IP 66, plug M12x1
										T2	Aluminum housing, IP 66, plug 7/8"
										T3	AISI 316L housing, IP 66, plug 7/8"
90										<b>Additional option:</b>	
										0	Basic version
										5	200 inch connecting cable with housing adapter, NEMA 6P, separate electronics
										7	...inch connecting cable with housing adapter, NEMA 6P, separate electronics, max. 800 inch
										A	Basic version, adjusted measuring range
										D	200 inch connecting cable with housing adapter, NEMA 6P, separate electronics, adjusted measuring range
DB50S											Complete order code

## DB51A – rod version

10	<b>Approval:</b>			
	A	Version for non-hazardous area		
	N	ATEX II 3 G EEx nA II T6		
	O	FM IS, Class I, Division 1, 2, Groups A – D		
	S	CSA IS, Class I, Division 1, Groups A – D		
	T	CSA IS, Class I, Division 2, Groups A – D		
20	<b>Probe:</b>			
		Probe length 16 to 160 inch		
	G	... inch, AISI 316L		
30	<b>Process connection:</b>			
		<b>Threaded connection</b>		
	12	ANSI 1 1/2 NPT, AISI 316L		
		<b>ANSI flanges</b>		
	30	1 1/2" 150 lbs RF, AISI 316/316L		
	31	2" 150 lbs RF, AISI 316/316L		
	32	3" 150 lbs RF, AISI 316/316L		
	33	4" 150 lbs RF, AISI 316/316L		
		<b>JIS flanges</b>		
	7C	JIS 10 K 50 A RF, AISI 316L		
40	<b>Measuring range:</b>			
		FA	0 to 1.5 psi/1 mH <sub>2</sub> O/40 inH <sub>2</sub> O	
		FB	0 to 6 psi/4 mH <sub>2</sub> O/160 inH <sub>2</sub> O	
		FC	0 to 15 psi/12 mH <sub>2</sub> O/480 inH <sub>2</sub> O	
		FD	0 to 60 psi/40 mH <sub>2</sub> O/1600 inH <sub>2</sub> O	
		FE	0 to 150 psi/100 mH <sub>2</sub> O/4000 inH <sub>2</sub> O	
		GA	-1.5 to 1.5 psi/1 mH <sub>2</sub> O/40 inH <sub>2</sub> O	
		GB	-6 to 6 psi/4 mH <sub>2</sub> O/160 inH <sub>2</sub> O	
		GC	-13 to 15 psi/12 mH <sub>2</sub> O/480 inH <sub>2</sub> O	
		GD	-13 to 60 psi/40 mH <sub>2</sub> O/1600 inH <sub>2</sub> O	
		GE	-13 to 150 psi/100 mH <sub>2</sub> O/4000 inH <sub>2</sub> O	
50	<b>Linearity; Fill fluid:</b>			
		1	< 0.2 % of measuring range; FDA compliant	
		2	< 0.2 % of measuring range; inert oil	
		3	< 0.1 % of measuring range; FDA compliant	
		4	< 0.1 % of measuring range; inert oil	
		Z	Additional specification	
60	<b>Measuring sensor seal:</b>			
		1	Viton	
		2	EPDM	
		5	Kalrez	
		3	Sensor welded	
70	<b>Electronics; Output:</b>			
		<b>Electronic inserts without integrated overvoltage protection</b>		
	A	Without integrated electronic insert (e.g. for ordering spare parts)		
	B	FEB11, 3-wire analog signal		
	C	FEB17, 2-wire PFM signal		
	E	FEB22, 4 to 20 mA, HART		
	G	FEB22, 4 to 20 mA, HART, with FHB20 onsite display		
	H	FEB24, PROFIBUS PA		
	K	FEB24, PROFIBUS PA, with FHB20 onsite display		
	1	FEB26, FOUNDATION Fieldbus		
	2	FEB26, FOUNDATION Fieldbus, with FHB20 onsite display		
		<b>Electronic inserts with integrated overvoltage protection</b>		
	M	FEB11P, 3-wire analog signal		
	N	FEB17P, 2-wire PFM signal		
	R	FEB22P, 4 to 20 mA, HART		
	T	FEB22P, 4 to 20 mA, HART, with FHB20 onsite display		
	U	FEB24P, PROFIBUS PA		
	W	FEB24P, PROFIBUS PA, with FHB20 onsite display		
DB51A				Order code

→For continuation of ordering information for DB51A, see the following page.

**DB51A – rod version  
(continued)**

80										<b>Housing; Cable entry:</b>	
										A0	Without housing (e.g. for ordering spare parts)
										E1	Polyester housing NEMA 4X, thread 1/2 NPT
										E2	Aluminum housing NEMA 4X, thread 1/2 NPT
										E3	AISI 316L housing, NEMA 4X, thread 1/2 NPT
										P2	Aluminum housing, IP 66, plug M12x1
										P3	AISI 316L housing, IP 66, plug M12x1
										T2	Aluminum housing, IP 66, plug 7/8"
										T3	AISI 316L housing, IP 66, plug 7/8"
90										<b>Additional option:</b>	
										0	Basic version
										5	200 inch connecting cable with housing adapter, NEMA 6P, separate electronics
										7	...inch connecting cable with housing adapter, NEMA 6P, separate electronics, max. 800 inch
										A	Basic version, adjusted measuring range
										D	200 inch connecting cable with housing adapter, NEMA 6P, separate electronics, adjusted measuring range
DB51A											Complete order code

**DB52A – cable version with process connection**

10	<b>Approval:</b>			
	A	Version for non-hazardous area		
	N	ATEX II 3 G EEx nA II T6		
	O	FM IS, Class I, Division 1, 2, Groups A – D		
	S	CSA IS, Class I, Division 1, Groups A – D		
	T	CSA IS, Class I, Division 2, Groups A – D		
20	<b>Probe:</b>			
	P	... inch FEP extension cable (probe length: 20 to 7874 inch)		
	R	... inch PE extension cable (probe length: 20 to 7874 inch)		
	S	... inch FEP extension cable for EEx ia, CSA IS, FM IS (probe length: 20 to 3937 inch)		
	T	... inch PE extension cable for EEx ia, CSA IS, FM IS (probe length: 20 to 3937 inch)		
30	<b>Process connection:</b>			
		<b>Threaded connection</b>		
	12	ANSI 1 1/2 NPT, AISI 316L		
		<b>ANSI flanges</b>		
	30	1 1/2" 150 lbs RF, AISI 316/316L		
	31	2" 150 lbs RF, AISI 316/316L		
	32	3" 150 lbs RF, AISI 316/316L		
	33	4" 150 lbs RF, AISI 316/316L		
40	<b>Measuring range:</b>			
	FA	0 to 1.5 psi/1 mH <sub>2</sub> O/40 inH <sub>2</sub> O		
	FB	0 to 6 psi/4 mH <sub>2</sub> O/160 inH <sub>2</sub> O		
	FC	0 to 15 psi/12 mH <sub>2</sub> O/480 inH <sub>2</sub> O		
	FD	0 to 60 psi/40 mH <sub>2</sub> O/1600 inH <sub>2</sub> O		
	FE	0 to 150 psi/100 mH <sub>2</sub> O/4000 inH <sub>2</sub> O		
	GA	-1.5 to 1.5 psi/1 mH <sub>2</sub> O/40 inH <sub>2</sub> O		
	GB	-6 to 6 psi/4 mH <sub>2</sub> O/160 inH <sub>2</sub> O		
	GC	-13 to 15 psi/12 mH <sub>2</sub> O/480 inH <sub>2</sub> O		
	GD	-13 to 60 psi/40 mH <sub>2</sub> O/1600 inH <sub>2</sub> O		
	GE	-13 to 150 psi/100 mH <sub>2</sub> O/4000 inH <sub>2</sub> O		
50	<b>Linearity; Fill fluid:</b>			
	1	< 0.2 % of measuring range; FDA compliant		
	2	< 0.2 % of measuring range; inert oil		
	3	< 0.1 % of measuring range; FDA compliant		
	4	< 0.1 % of measuring range; inert oil		
	Z	Additional specification		
60	<b>Measuring sensor seal:</b>			
	1	Viton		
	2	EPDM		
	5	Kalrez		
	3	Sensor welded		
70	<b>Electronics; Output:</b>			
		<b>Electronic inserts without integrated overvoltage protection</b>		
	A	Without integrated electronic insert (e.g. for ordering spare parts)		
	B	FEB11, 3-wire analog signal		
	C	FEB17, 2-wire PFM signal		
	E	FEB22, 4 to 20 mA, HART		
	G	FEB22, 4 to 20 mA, HART, with FHB20 onsite display		
	H	FEB24, PROFIBUS PA		
	K	FEB24, PROFIBUS PA, with FHB20 onsite display		
	1	FEB26, FOUNDATION Fieldbus		
	2	FEB26, FOUNDATION Fieldbus, with FHB20 onsite display		
		<b>Electronic inserts with integrated overvoltage protection</b>		
	M	FEB11P, 3-wire analog signal		
	N	FEB17P, 2-wire PFM signal		
	R	FEB22P, 4 to 20 mA, HART		
	T	FEB22P, 4 to 20 mA, HART, with FHB20 onsite display		
U	FEB24P, PROFIBUS PA			
W	FEB24P, PROFIBUS PA, with FHB20 onsite display			
DB51A				Order code

→For continuation of ordering information for DB52A, see the following page.

**DB52A – cable version with process connection (continued)**

80										<b>Housing; Cable entry:</b>	
										A0	Without housing (e.g. for ordering spare parts)
										E1	Polyester housing NEMA 4X, thread 1/2 NPT
										E2	Aluminum housing NEMA 4X, thread 1/2 NPT
										E3	AISI 316L housing, NEMA 4X, thread 1/2 NPT
										P2	Aluminum housing, IP 66, plug M12x1
										P3	AISI 316L housing, IP 66, plug M12x1
										T2	Aluminum housing, IP 66, plug 7/8"
										T3	AISI 316L housing, IP 66, plug 7/8"
90										<b>Additional option:</b>	
										0	Basic version
										5	200 inch connecting cable with housing adapter, NEMA 6P, separate electronics
										7	...inch connecting cable with housing adapter, NEMA 6P, separate electronics, max. 800 inch
										A	Basic version, adjusted measuring range
										D	200 inch connecting cable with housing adapter, NEMA 6P, separate electronics, adjusted measuring range
DB52A										Complete order code	

## DB53A – cable version with suspension clamp

10	<b>Approval:</b>		
	A	Version for non-hazardous area	
	N	ATEX II 3 G EEx nA II T6	
	O	FM IS, Class I, Division 1, 2, Groups A – D	
	S	CSA IS, Class I, Division 1, Groups A – D	
T	CSA IS, Class I, Division 2, Groups A – D		
20	<b>Probe:</b>		
	P	... inch FEP extension cable (probe length: 20 to 7874 inch)	
	R	... inch PE extension cable (probe length: 20 to 7874 inch)	
	S	... inch FEP extension cable for EEx ia, CSA IS, FM IS (probe length: 20 to 3937 inch)	
T	... inch PE extension cable for EEx ia, CSA IS, FM IS (probe length: 20 to 3937 inch)		
30	<b>Process connection:</b>		
	70	Cable probe without suspension clamp	
	71	Suspension clamp AISI 316L	
7C	Flange JIS 10 K 50 A RF, AISI 316L		
40	<b>Measuring range:</b>		
	FA	0 to 1.5 psi/1 mH <sub>2</sub> O/40 inH <sub>2</sub> O	
	FB	0 to 6 psi/4 mH <sub>2</sub> O/160 inH <sub>2</sub> O	
	FC	0 to 15 psi/12 mH <sub>2</sub> O/480 inH <sub>2</sub> O	
	FD	0 to 60 psi/40 mH <sub>2</sub> O/1600 inH <sub>2</sub> O	
FE	0 to 150 psi/100 mH <sub>2</sub> O/4000 inH <sub>2</sub> O		
50	<b>Linearity; Fill fluid:</b>		
	1	< 0.2 % of measuring range; FDA compliant	
	2	< 0.2 % of measuring range; inert oil	
	3	< 0.1 % of measuring range; FDA compliant	
	4	< 0.1 % of measuring range; inert oil	
Z	Additional specification		
60	<b>Measuring sensor seal:</b>		
	1	Viton	
	2	EPDM	
	5	Kalrez	
3	Sensor welded		
70	<b>Electronics; Output:</b>		
	<b>Electronic inserts without integrated overvoltage protection</b>		
	A	Without integrated electronic insert (e.g. for ordering spare parts)	
	B	FEB11, 3-wire analog signal	
	C	FEB17, 2-wire PFM signal	
	E	FEB22, 4 to 20 mA, HART	
	G	FEB22, 4 to 20 mA, HART, with FHB20 onsite display	
	H	FEB24, PROFIBUS PA	
	K	FEB24, PROFIBUS PA, with FHB20 onsite display	
	1	FEB26, FOUNDATION Fieldbus	
	2	FEB26, FOUNDATION Fieldbus, with FHB20 onsite display	
	<b>Electronic inserts with integrated overvoltage protection</b>		
	M	FEB11P, 3-wire analog signal	
	N	FEB17P, 2-wire PFM signal	
	R	FEB22P, 4 to 20 mA, HART	
T	FEB22P, 4 to 20 mA, HART, with FHB20 onsite display		
U	FEB24P, PROFIBUS PA		
W	FEB24P, PROFIBUS PA, with FHB20 onsite display		
DB53A			Order code

→For continuation of ordering information for DB53A, see the following page.

**DB53A – cable version with suspension clamp (continued)**

80										<b>Housing; Cable entry:</b>	
										A0	Without housing (e.g. for ordering spare parts)
										E1	Polyester housing NEMA 4X, thread 1/2 NPT
										E2	Aluminum housing NEMA 4X, thread 1/2 NPT
										E3	AISI 316L housing, NEMA 4X, thread 1/2 NPT
										P2	Aluminum housing, IP 66, plug M12x1
										P3	AISI 316L housing, IP 66, plug M12x1
										T2	Aluminum housing, IP 66, plug 7/8"
										T3	AISI 316L housing, IP 66, plug 7/8"
90										<b>Additional option:</b>	
										0	Basic version
										A	Basic version, adjusted measuring range
DB53A											Complete order code

## Accessories

### Display and operating module FHB20

The FHB20 display and operating module is available for onsite operation for the following electronic inserts.

- HART – FEB22(P)
- PROFIBUS PA – FEB24(P)
- FOUNDATION Fieldbus – FEB26
- Material: POM (polyoxymethylene)
- Order number: 942512-0100

Note!

- The display and operating module only fits under a cover with a sight glass (high cover), see this chapter, "Cover with sight glass" section. If you order the FHB20 onsite display by means of the order structure, the Deltapilot S with a high cover is delivered (→ see Page 37, "Ordering information" chapter, feature 70 "Electronic insert").
- Once you have configured a device with the FHB20 display and operating module, you can remove the display and use it to configure other devices. Only remove the display from an electronic insert, or attach it to an electronic insert, in a deenergized state.
- → See also Page 10, "Human interface" chapter.

### Cover with sight glass (high cover)

Cover with sight glass depending on the housing version:

	For aluminum housing	For polyester housing	For stainless steel housing
Material	EN AC-44200 with synthetic coating, gray, sight glass: glass	Cover (transparent): polycarbonate (PC)	AISI 316L (1.4404), sight glass: glass
Order number	942828-0010	942828-0001	942828-0100

### Housing adapter with mounting bracket for humid, damp and difficult-to-access mounting locations

With the housing adapter and mounting bracket, you have the option of mounting the housing with the electronic insert away from the measuring point. This allows problem-free measurement

- under particularly difficult measuring conditions (in confined or difficult-to-access mounting locations)
- in the event of extreme fluctuations in temperature at the tank wall

IP 68 protection applies for the housing adapter. The mounting bracket is suitable for pipe and wall mounting.  
→ See also page 19, "Housing adapter with mounting bracket" section and Page 31, "Dimensions" section.

Order code	Version
HDB50-A	5 m PE cable with mounting bracket AISI 304 (1.4301)
HDB50-B	... m PE cable (1 to 30 m) with mounting bracket AISI 304 (1.4301)
HDB50-C	5 m FEP cable with mounting bracket AISI 304 (1.4301)
HDB50-D	... m FEP cable (1 to 30 m) with mounting bracket AISI 304 (1.4301)

### Mounting bracket

Mounting bracket for pipe and wall mounting:

- Material: AISI 304 (1.4301)
- Order number: 919806-1000

→ See also Page 19, "Housing adapter with mounting bracket" section and Page 30, "Dimensions of Deltapilot S DB53 and DB53 (A) "Suspension clamp and mounting bracket" section.

### Extension cable shortening kit

Extension cable shortening kit for cable between housing adapter and mounting bracket:

- Order number: 935666-0020

### Suspension clamp

Suspension clamp for Deltapilot S DB53:

- Material: stainless steel AISI 316L (1.4435), clamping jaw: fiberglass reinforced PA (polyamide)
- Order number: 52010869

→ See also Page 30, "Dimensions of Deltapilot S DB53 and DB53(A) "Suspension clamp and mounting bracket" section.



**Protective cover**

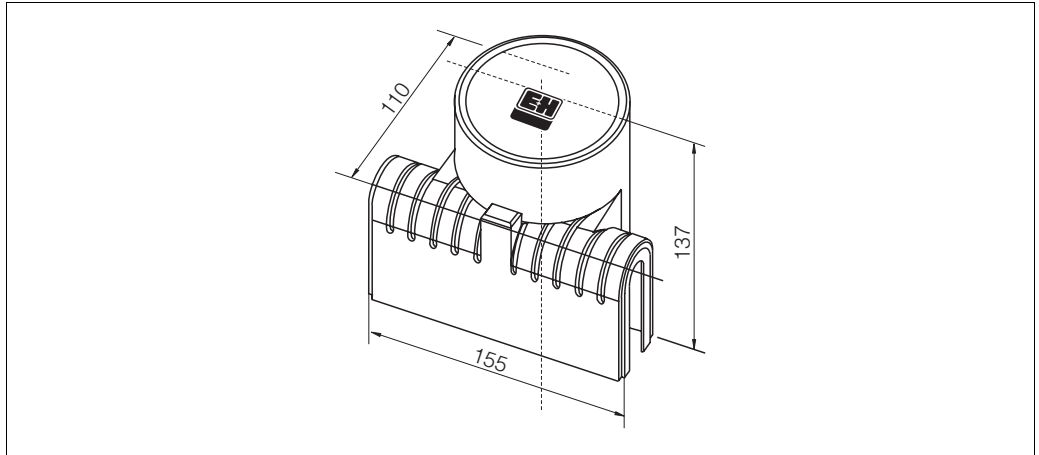

P01-DB5xxxx-00-xx-xx-xx-001

*Protection cover*

For the aluminum and polyester housing, Endress+Hauser offers protective covers with two cable entries.

- Max. ambient temperature: +70°C (+158°F)
- Material: polyamide (PA)
- Order number for protection cover for devices with a flat cover: 942262-0000
- Order number for protection cover for devices with a high cover: 942262-0001

**Welding flanges**

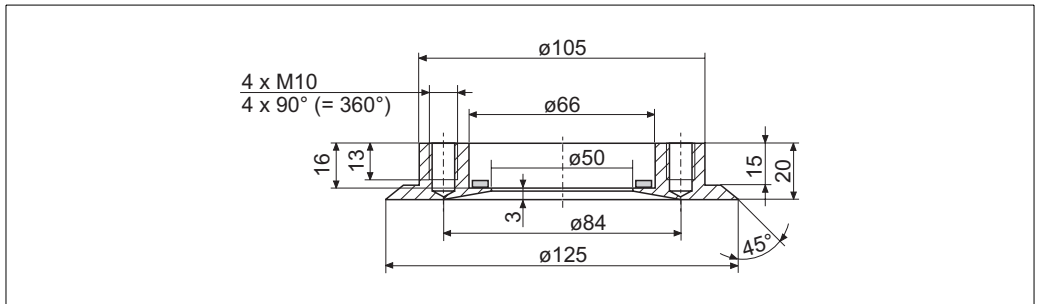

P01-DB5xxxx-00-xx-xx-xx-032

*Welding flange for flush-mounted installation for devices with a DRD flange.*

Version	Order number
DRD DN 50, AISI 316L (1.4435)	52002041
DRD DN 50, 3.1, AISI 304 (1.4301)	52011899
DRD DN 50, AISI 304 (1.4301)	916743-0000

Note!

- Order number for a replacement PTFE flat seal: 916783-0000

### Welding neck adapter for universal process adapter

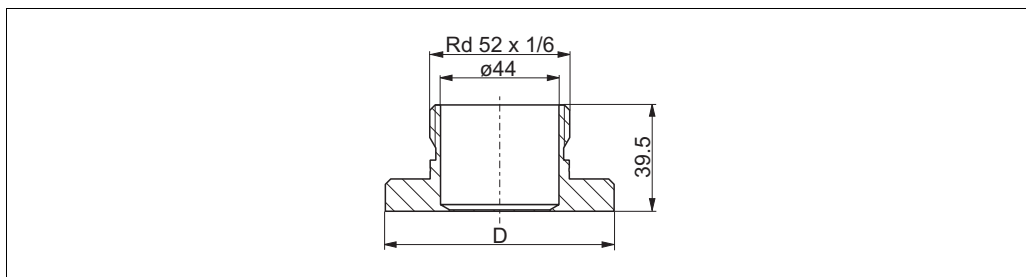

P01-PMC45xxx-06-xx-xx-xx-000

Welding neck adapter for flush mounting a Deltapilot S DB50L/DB50S with a universal process adapter

Diameter D	Material	Order number
65 mm	AISI 316L	214880-0002
65 mm	AISI 316L with inspection certificate EN 10204 3.1 material	52010174
85 mm	AISI 316L	52006262
85 mm	AISI 316L with inspection certificate EN 10204 3.1 material	52010173

### Welding neck adapter thread ISO G 1 1/2

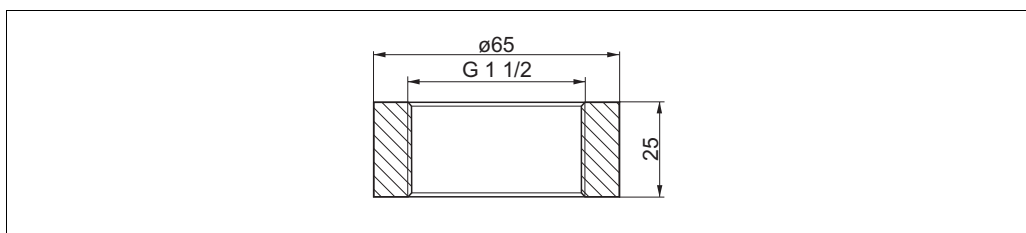

P01-PM4xxxx-06-09-xx-xx-000

Welding neck adapter for flush mounting a Deltapilot S DB50 with thread ISO 228 G 1 1/2 A  
Order number: 52024469, order number with 3.1 inspection certificate: 52024470

#### Note!

- Endress+Hauser offers a pressure sensor dummy for the welding necks with order numbers 52024469 and 52024470. Order number for pressure sensor dummy: 52024471

### Adapter

You can use the following adapters to mount a DB50L with a universal process connection in a DRD, dairy fitting or Clamp connection:

Version	Order number
DRD 65 mm, AISI 304 (1.4301)	917656-0001
Dairy fitting DIN 11851 DN 40, AISI 304 (1.4301)	917656-0002
Dairy fitting DIN 11851 DN 50, AISI 304 (1.4301)	917656-0000
Tri-Clamp ISO 2852 DN 40-51 (2")/DIN 32676 DN 50, AISI 304 (1.4301)	917650-0002

## Documentation

<b>Field of Activities</b>	<ul style="list-style-type: none"> <li>■ Pressure measurement, powerful measuring devices for process pressure, differential pressure, level and flow: FA004P/00/en</li> </ul>
<b>Technical Information on switching unit</b>	<ul style="list-style-type: none"> <li>■ Level measurement, silometer FMC4120: TI077F/00/en</li> <li>■ Level measurement, Prolevel FMB662: TI234F/00/en</li> </ul>
<b>Operating Instructions</b>	<ul style="list-style-type: none"> <li>■ Deltapilot S HART: BA152P/00/en</li> <li>■ Deltapilot S PROFIBUS PA: BA164F/00/en</li> <li>■ Deltapilot S FOUNDATION Fieldbus: BA232F/00/en</li> <li>■ PROFIBUS DP/PA, Guidelines for planning and commissioning: BA034S/04/en</li> <li>■ FOUNDATION Fieldbus Overview, Installation and Commissioning Guidelines: BA013S/04/en</li> </ul>

### Safety Instructions

Certificate/explosion protection	Device	Electronics	Documentation
ATEX II 1/2 G EEx ia IIC T6	DB50, DB50L, DB51, DB52	<ul style="list-style-type: none"> <li>– PFM</li> <li>– 4 to 20 mA HART</li> <li>– PROFIBUS PA</li> <li>– FOUNDATION Fieldbus</li> </ul>	<ul style="list-style-type: none"> <li>– XA002F</li> <li>– XA002F</li> <li>– XA007F</li> <li>– XA135F</li> </ul>
ATEX II 2 G EEx ia IIC T6	DB53	<ul style="list-style-type: none"> <li>– PFM</li> <li>– 4 to 20 mA HART</li> <li>– PROFIBUS PA</li> <li>– FOUNDATION Fieldbus</li> </ul>	<ul style="list-style-type: none"> <li>– XA002F</li> <li>– XA002F</li> <li>– XA007F</li> <li>– XA135F</li> </ul>
ATEX 1/2 G EEx nA II T6	DB50, DB50L, DB51, DB52, DB53	<ul style="list-style-type: none"> <li>– PFM</li> <li>– 4 to 20 mA HART</li> <li>– PROFIBUS PA</li> <li>– FOUNDATION Fieldbus</li> </ul>	<ul style="list-style-type: none"> <li>– XA189F</li> <li>– XA189F</li> <li>– XA189F</li> <li>– XA189F</li> </ul>
ATEX II 1/2 G EEx ia IIB T6	DB52	<ul style="list-style-type: none"> <li>– PFM</li> <li>– 4 to 20 mA HART</li> <li>– PROFIBUS PA</li> <li>– FOUNDATION Fieldbus</li> </ul>	<ul style="list-style-type: none"> <li>– XA002F</li> <li>– XA002F</li> <li>– XA007F</li> <li>– XA135F</li> </ul>

### Installation Drawings/ Control Drawings

Certificate/explosion protection	Device	Electronics	Documentation
CSA IS Class I, Division 1, Groups A-D	DB50(A), DB50L, DB50S, DB51(A), DB 52(A), DB53(A)	<ul style="list-style-type: none"> <li>– PFM</li> <li>– 4 to 20 mA HART</li> <li>– PROFIBUS PA</li> <li>– FOUNDATION Fieldbus</li> </ul>	<ul style="list-style-type: none"> <li>– Order number: 016586-0000</li> <li>– Order number: 960351-1034</li> <li>– ZD036F + ZD021F</li> <li>– ZD068F + ZD021F</li> </ul>
FM IS Class I, Division 1, 2 Groups A-D	DB50A, DB50S, DB51A, DB52A, DB53A	<ul style="list-style-type: none"> <li>– PFM</li> <li>– 4 to 20 mA HART</li> <li>– PROFIBUS PA</li> <li>– FOUNDATION Fieldbus</li> </ul>	<ul style="list-style-type: none"> <li>– Order number: 017054-0000</li> <li>– Order number: 017054-0000</li> <li>– ZD024F + ZD021F</li> <li>– ZD067F + ZD021F</li> </ul>

### Overfill protection

- WHG: ZE217F/00/en: HART
- WHG: ZE238F/00/en: PROFIBUS PA

**Deutschland**

Endress+Hauser  
Messtechnik  
GmbH+Co. KG  
Colmarer Str. 6  
79576 Weil am Rhein  
Fax 0800 EHFAXEN  
Fax 0800 3 43 29 36  
www.de.endress.com

Vertrieb  

- Beratung
- Information
- Auftrag
- Bestellung

Tel. 0800 EHVERTRIEB  
Tel. 0800 3 48 37 87  
info@de.endress.com

Service  

- Help-Desk
- Feldservice
- Ersatzteile/Reparatur
- Kalibrierung

Tel. 0800 EHSERVICE  
Tel. 0800 3 47 37 84  
service@de.endress.com

Technische Büros  

- Hamburg
- Hannover
- Ratingen
- Frankfurt
- Stuttgart
- München
- Berlin

**Österreich**

Endress+Hauser  
Ges.m.b.H.  
Lehnergasse 4  
1230 Wien  
Tel. +43 1 88 05 60  
Fax +43 1 88 05 63 35  
info@at.endress.com  
www.at.endress.com

**Schweiz**

Endress+Hauser  
Metso AG  
Sternenhofstraße 21  
4153 Reinach/BL 1  
Tel. +41 61 7 15 75 75  
Fax +41 61 7 11 16 50  
info@ch.endress.com  
www.ch.endress.com

# Endress+Hauser

People for Process Automation

