

Gas burner safety control

INTRODUCTION

MMG 870.1 gas burner safety controls are suitable for fully automatic forced and induced draught gas burners which have an intermittent (expanding flame) pilot system.

The MMG 870.1 control box provides a safe light-up and shutdown sequence for the burner and incorporates pre-purge, ignition and ignition safety time intervals, start gas flame and main flame stages.

The control box is equipped to handle U-V (ultra-violet) or flame ionisation methods of flame detection. For U-V detection, the Satronic UVZ 780 (red) detector must be used.

MMG 870.1 mod 65 is certificated for use in the United Kingdom.

FEATURES

- In common with earlier ,MM' series controls, the timing sequence is controlled by a synchronous motor driving a cam switch assembly, this produces an accurate and consistent timing performance despite variations in the supply voltage.
- The control box checks the air pressure proving device in both the ,no air' and ,air supply' proved positions.
- A coloured programme indicator is incorporated to show the position reached by the control box at any stage in the sequence and this allows easier fault diagnosis.
- The main relay operates on d.c. and this assists in noiseless operation irrespective of supply voltage variations. The electrical and electronic components are mounted onto two plug-in printed circuit boards. Power to the external circuits e.g. gas valves, ignition system etc. is by ,point to point' internal wiring.
- The MMG 870.1 control box is also suitable for use with gas valve ,proof-of-closure' switches. This safety check is continuous throughout the pre-purge period.
- The control box is designed to largely ignore the effects of ignition spark interference upon the flame signal when used with the flame ionisation detection principle.
- The wiring base and control box have a positive plug-in arrangement preventing an incorrect connection between the two parts.
- In the wiring base, extra terminals for earth and neutral connections are supplied, in all, 2 for neutral and 3 for earth.
- The UVZ 780 U-V detector is of robust construction, well sealed against the ingress of dirt or other tracking media and is suitable for end-on or side-on viewing of the flame.



CONSTRUCTION

Control box and base

The control box is housed in a tough transparent plastic cover so that the working parts are easily seen. The plastic material used for the cover is of the self-extinguishing type. Inside, a synchronous motor and cam switch assembly provide the timing sequence. The electronic flame detection amplifier and electrical components are mounted onto two plug-in printed circuit boards, whilst power to the external circuits e.g. gas valves, ignition system etc. is carried through conventional point to point wiring.

Manual reset from the lockout position is provided by a push button on top of the control and a lockout signal lamp is placed underneath this button. A single screw through the control box locks it onto the wiring base.

The wiring base is a robust plastic moulding allowing adequate room when connecting up to the terminals supplied for live, neutral, earth, burner fan motor, gas valves etc. A variety of cable entry points is provided in the form of 4 easy knockout holes at the base ends and the underside. The base ends are for PG 11 screwed electrical fittings. In addition, a detachable cable entry plate is supplied which allows for either further screwed cable entry fittings or simple entries for p.v.c. type wiring.

Flame ionisation probe

This is not supplied as part of the control system. A flame electrode with both good heat resisting properties and high quality insulation should be used for this. The flame electrode should therefore be similar to a good quality ignition electrode.

UVZ 780 Detector

For ultra-violet flame detection, the Satronic UVZ 780 (red sensitivity code) should be used.

The detector consists a U-V sensing tube, 4 pin socket, capacitor, resistor and diode mounted in a tubular metal casing ensuring good earth contact through the burner.

The casing has 2 apertures which allow the U-V tube to ,see' the flame in either a side-on or end-on attitude.

Over the outer casing, an adjustable metal ring is supplied which enables the entire assembly to be adjusted to give an optimum flame viewing position for the U-V tube.

At the base of the UVZ detector, wiring terminals and a cable clamp are supplied beneath a removable cover plate. A mounting flange completes the assembly and this is keyed to locate with the adjustable ring.

Failure to establish flame

If flame is not established or detected during the light-up sequence, the control box goes to lockout, shutting down the burner within 5 seconds from the initial release of fuel &om the start gas valve.

The lockout signal lamp behind the reset button is displayed, and the burner cannot be restarted until the reset button pressed.

Reset can be effected immediately following a lockout and a full light-up sequence begins.

Running flame failure

If, during a run, the gas flame is extinguished, the flame detection system reacts almost immediately to the loss of flame. The gas valve circuits are de-energised within 1 second and the control box goes to lockout shutting down the burner completely. See also under ,Summary of safety features'.

INTERNAL & EXTERNAL WIRING DIAGRAM Fig.1

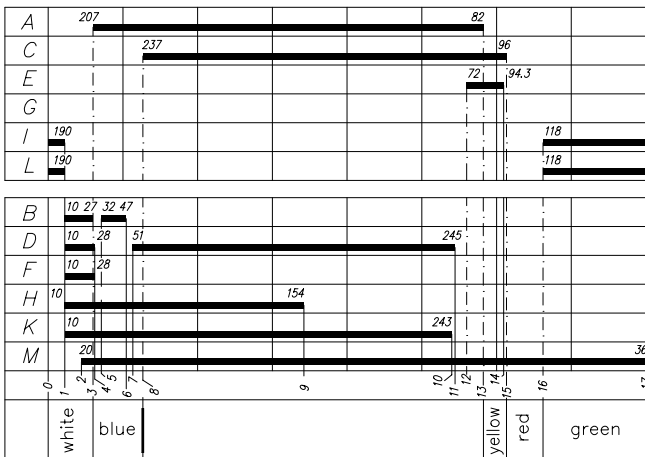

Coloured programme indicator

A coloured programme indicator is incorporated on the cam assembly, and the approximate colour positions indicate the following steps in the sequence:

- Blue line on white – Start position
- Start of blue sector – Start of pre-purge
- Red line in blue sector – Air supply proved see under fault finding, note 3
- Blue sector – Pre-purge
- End of blue – End of pre-purge
- Start of yellow – Initial fuel release and start of ignition safety time
- End yellow/start of red – Lockout position, due to ignition or flame detection failure
- Red sector – Start gas flame proving period
- End red/start of green – Main flame stage
- End green/start of white – ,Run' position

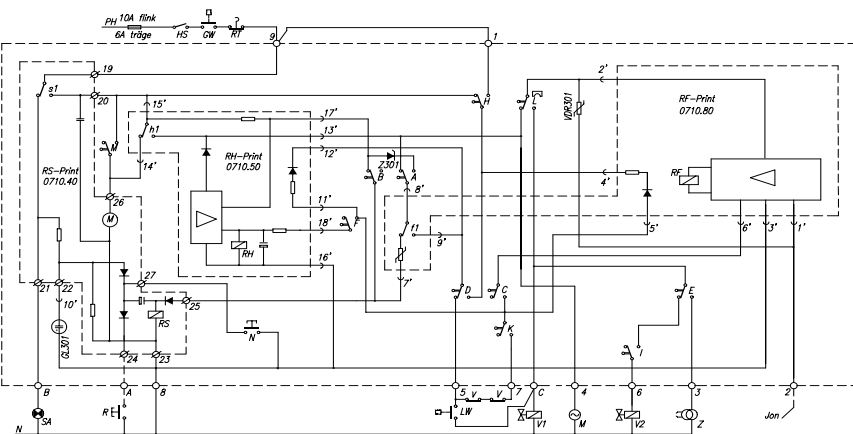

- HS Main isolator
- GW Gas pressure proving switch (if fitted)
- Th Control thermostat
- v Gas valve proof-of-closure switches (if fitted) see fig. 3
- SA External lockout signal
- LW Air pressure proving device
- V1 Start gas valve
- V2 Main gas valve
- Z Ignition transformer
- M Burner fan motor
- Ion Flame detection probe
- U-V U-V detector UVZ 780
- RS Lockout relay, with contacts sl
- RH Main relay, with contacts hl
- RF Flame relay, with contacts f1
- Sy Synchronous timing motor

INSTALLATION INSTRUCTIONS

Control box

1. The control box wiring base is supplied with 2 fixing holes for mounting onto the burner
2. To assist trouble-free operation, choose a position where the mcontrol box is not subject to undue vibration. Similarly, the mthe control should not be mounted where the ambient temperature exceeds 60° C.
3. Ensure the control box is correctly wired up in accordance with the appropriate diagram. A general diagram is provided on the underside of the control box, but it is advisable to also refer to the burner manufacturer's scheme drawing, in case additional external interlocks are required for correct burner operation.
4. The control box will only function providing a load is connected onto terminal ,C' e.g. start gas valve, see fig. 2. Similarly, if this load employs half-wave rectification the negative of the load must be connected onto terminal ,C'. 5. Observe correct wiring polarity of live and neutral, live onto terminal 9, neutral onto 8, see fig. 2.
6. Where the burner fan motor loading exceeds the control box current rating of 2 A, a contactor or starter must be used to switch the load. Similarly, if the motor is over 1/4 HP and is of the split-phase start variety, a contactor must be used to handle the electrical load.
7. Proof-of-closure switches on gas valves can be interlocked with the operation of the control box by connecting these switches between terminals 5 and 7, see fig. 3.
8. Where a timeswitch is fitted to control the burner, the timeswitch contacts should be placed in series with the control thermostat wiring to terminal 9.

Flame ionisation probe

1. For best results, the length of wiring run between flame probe and control box should be kept as short as possible. Maximum permissible length is 20 metres.
2. The flame probe should be well positioned in the flame, but as remote as is practical from the H.T. ignition electrode. The control box flame detection amplifier is suppressed for ,spark splash' onto the probe, nevertheless contact between H.T. ignition spark and the flame probe must be avoided.
3. Ensure the boiler/burner are effectively bonded to the incoming earth from the mains supply, otherwise little or no flame signal may result.
4. The wiring to the flame probe and H.T. ignition should not be run adjacent to each other.

UVZ 780 detector

1. Observe correct wiring polarity to the UVZ detector, + connection to terminal 2 on the control box, ñ connection to terminal 8 (neutral).
2. For best results, keep the length of wiring run between control box and detector as short as possible, max. cable run 20 metres, and if practical separate from other wiring.
3. The UVZ detector mounting flange should be in positive contact with the metallic parts of the burner to ensure a good earthing and screening effect.
4. The detector should be positioned such that it has direct sight of the gas flame. It should not be subjected to other external light sources which may contain U-V radiation, otherwise trouble-free operation will be prevented.
5. By use of the adjustable ring over the outer casing of the detector, it's positioning can be slightly altered to obtain optimum sighting of the flame.

EXTERNAL WIRING DIAGRAM Fig.2

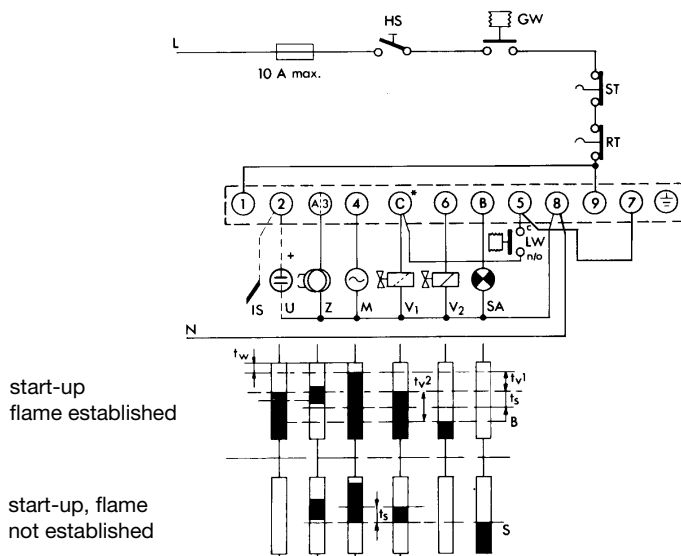

HS	Main Isolator
GW	Gas pressure proving switch, if fitted
ST	Limit thermostat
RT	Control thermostat
U	U-V detector, UVZ 780
IS	Flame detection probe
Z	Ignition Transformer
M	Burner fan motor
V1	Start gas valve
V2	Main gas valve
SA	External lockout signal
LW	Air pressure proving device
B	„Run“ position
S	„Lockout“ position

tw	Waiting time at start position
tv1	Pre-purge period
ts	Ignition safety time
tv2	Delay to main flame V2

Use with proof of closure switches Fig.3

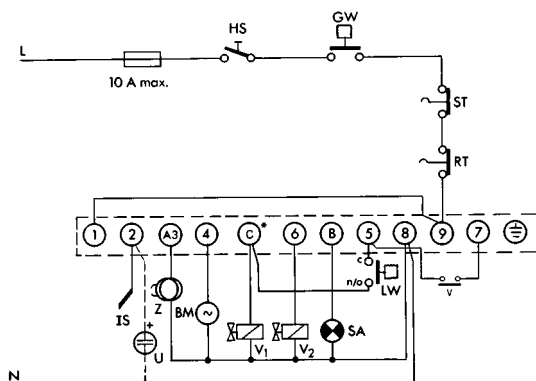

Refer generally, but the following additional information applies.

- V Gas valve proof-of-closure switches
When used with proof-of-closure switches, the external wiring must be in accordance with the above diagram, the proof-of-closure switch(es) ,v' connected between terminals 5 and 7 as shown.
This arrangement will maintain the check for gas valve closure throughout the pre-purge period. In the event that this check is not satisfied, the control box will go to lockout.

***Note:** This control will only function correctly providing a load, e.g. start gas valve, is connected onto terminals 5 or C. If this load employs a half-wave rectifier, the negative side of the load must be connected to 5 or C.

COMMISSIONING AND ROUTINE CHECKS

Generally the control box should not require any maintenance and no attempt should be made to break the seal or remove the cover. On commissioning and during each routine service visit it is advisable to carry out the following checks which should only be done by a competent Service Engineer.

1. Close the main gas cock, link out the gas pressure switch, if fitted, and allow the burner to start. The control box should go to lockout after expiry of the ignition safety time.
2. Re-open the main gas cock, reset the control box from lockout allowing the burner to start. When the burner is at the 'run' position, close the main gas cock. When the flame goes out, the control box should go to lockout almost immediately. Remove the link across the gas pressure proving switch, if fitted.
3. Allow the burner to start, and during the pre-purge period, simulate a failure in the combustion air supply. The control box should go to lockout almost immediately.
4. Re-start the burner and during the pre-purge simulate, if possible, a false flame signal. The burner should shutdown immediately with the control box going to lockout. Remove the source of flame simulation.
5. Before attempting to start the burner, simulate combustion air supply established. The control box synchronous motor will run but start up of the burner will be prevented. Remove source of air supply simulation.

Notes on flame detection

A flame detection or ionisation probe is simply a metal electrode which is positioned in the flame. When an a.c. voltage is applied between the burner and probe, a d.c. current flows through the probe via the flame to the burner (earth). The flame therefore acts as a rectifier and the resulting d.c. current is amplified such that it is sufficient to operate the flame relay within the burner control box. If the insulation between the flame probe and earth is insufficient, leakage currents will occur and these will be a.c.

A filter incorporated in the control box flame detection amplifier will separate leakage currents from the ionisation current. In cases of 'short circuit' between probe and the burner, the rectifying action will not take place and the control box reacts as if 'loss of flame' has occurred.

An ultra-violet detector comprises a discharge tube enclosed within a bulb which will allow the passage of U-V radiation. Without the presence of U-V radiation, the applied voltage to the U-V detector is well below its normal ignition or discharge voltage. On receiving a U-V source, the ignition voltage value is lowered and the tube discharges. A current flows through the tube, over a rectifier at the base of the detector and after amplification the flame relay inside the control box operates.

It is usual to apply a higher than normal voltage ('test voltage') to the tube during each cycle to detect a potentially faulty tube before danger to the safe working of the system can arise. The rectifier at the base of the detector prevents danger from leakage or short circuit currents. The filter and amplifier react only to d.c. or uni-directional currents and not to a.c. currents which leakage effects and short circuits produce.

Interference to flame signal - flame ionisation probe

One possible source of problem with this system, is interference to the flame signal from the ignition spark. The ignition spark may produce its own ionisation current, the polarity of which is often random and can therefore oppose and possibly swamp the flame signal current. The result of this will often be a 'nuisance lockout'. The MMG 870.1 control box is designed to limit this problem to a minimum. During the ignition sequence, the flame relay is purposely energised at the commencement of the ignition safety time. Just prior to the lockout position being reached, the ignition circuit is switched off. This provides the flame detection system with a brief period to react to a flame signal which will then be free from ignition interference and allows the flame relay to be maintained if flame is detected at this point.

The Satronic ZI' 812 High Frequency Ignition System, see leaflet A 12 also eliminates the effect of spark interference. The output voltage is so arranged that any ionisation current from the spark is polarised to be in the same direction as the flame signal current.

Measurement of flame signal current

To ensure good sighting of the flame by the UVZ detector, or effective positioning of the flame probe, a simple current measurement can be taken. To obtain realistic values, this is best carried out after the ignition circuit has been switched off.

Figs. 4 & 5 below show the method, using a d.c. microammeter with ranges 0.....10 μ A and 0.....100 μ A.

Fig. 4 Ionisation-signal current

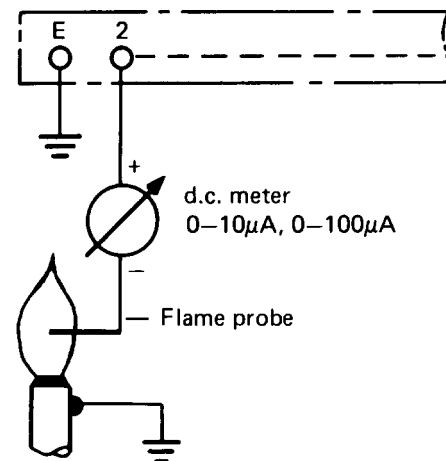
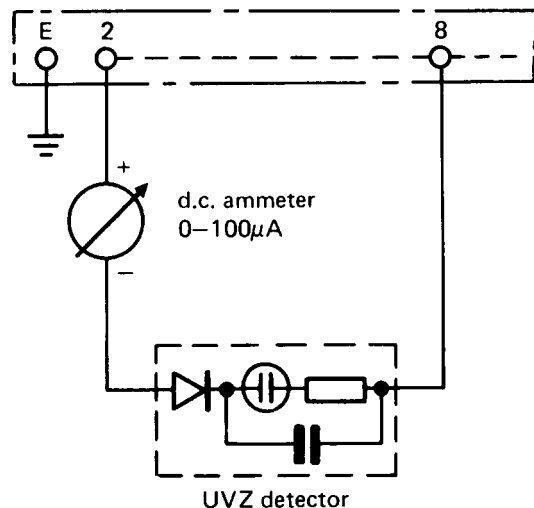

Fig. 5 U-V signal current



SUMMARY OF SAFETY FEATURES

1. Flame failure during a run results in burner shutdown and lockout within 1 second.
2. Failure to detect or establish flame during the light-up sequence, results in burner shutdown and lockout within a maximum of 5 seconds from the initial release of fuel.
3. Combustion air supply failure at any time results in burner shutdown and immediate lockout.
4. The air pressure proving device on the burner is checked in both the 'no air' and 'air supply proved' positions. From the initial start up of the burner fan motor, a period of approx. 5 seconds is allowed by the control box for the air proving device to detect a combustion air supply.
5. Restoration of the power supply after an interruption results in a full light-up sequence to safely restart the burner. Power failure after a lockout will not interfere with this condition when the supply is restored.
6. False flame signals at the start and during the pre-purge period result in burner shutdown and lockout.
7. The light-up sequence can only commence providing the cam switches and relay contacts in the control box are in their correct relative positions and continuity of the lockout relay circuit is proved.
8. When used with gas valve proof-of-closure switches, the check for valve closure is continuous throughout the pre-purge period and failure to satisfy this check results in lockout.

FAULT FINDING

1. Burner will not start.
Coloured programme indicator stopped on blue line in white sector.
 - a. Check electrical supply is switched on.
 - b. Check that thermostat circuit is 'calling for heat' and timeswitch contacts are made. A supply on terminal 9 will determine this.
2. Burner will not start.
Synchronous motor runs, coloured programme indicator rotates but burner does not start.
 - a. Check air pressure proving device is in 'no air' position.
 - b. Check that terminals 9 and 1 are linked, see figs. 2 & 3.
3. Burner starts but goes to lockout.
Programme indicator stopped on red line in blue sector.
 - a. Check air pressure proving device.
 - b. Check that load, e.g. start gas valve, is connected onto terminal 'C' and that continuity of start gas valve coil is O.K.
 - c. If start gas valve has half-wave rectifier, check that the negative side is connected onto 'C'.
 - d. Check for false flame signal or flame simulation.
 - e. Check proof-of-closure switch on gas valve(s).
4. Burner starts but goes to lockout. Coloured programme indicator stopped in blue sector.
 - a. Check for combustion air supply failure.
 - b. Check for flame simulation, if necessary change control box.
 - c. Check for continuity of start gas valve coil circuit.
 - d. Check proof-of-closure switch(es) on gas valves.

5. Burner starts, flame established but control box goes to lockout
Coloured programme indicator stopped at end of yellow/start of red sector.
 - a. Check flame detection probe is in contact with flame.
 - b. Check that flame probe insulation is not cracked. Damage to insulation could give rise to a.c. leakage current, see notes on flame detection principles.
 - c. Check that flame probe is not in contact with other metallic parts of the burner.
 - d. Check U-V detector is correctly wired up and is properly positioned to 'see' the flame.
6. Burner starts, flame established but control box goes to lockout.
Coloured programme indicator stopped in red sector.
Check that when main gas valve has been switched on, the change in combustion or flame characteristics has not caused the flame to lift off the combustion head and hence allow the flame probe to lose contact with the flame.
7. Burner starts, runs, but subsequently goes to lockout.
Coloured programme indicator stopped at end of green/start of white sector.
 - a. Check for interruption in gas supply.
 - b. Check for failure of combustion air supply.
 - c. Check if flame probe insulation is sound.
 - d. Check flame probe position in flame.
 - e. If necessary change control box.
 - f. Check U-V detector, replace if necessary.

Note If the control box goes to lockout, it is generally performing the function it is designed for.

Causes of lockout

1. No ignition.
2. Ignition spark not in correct place, check electrode settings, and ceramic insulation for cracks or other damage.
3. No gas supply
4. Gas valves not opening when energised
5. Failure of combustion air supply
6. Incorrectly positioned flame probe detector, poor earth contact with flame, interference to flame signal from ignition spark
7. Faulty control box
8. Faulty U-V detector
9. Gas valve proof-of-closure check not satisfied

Special note

The MMG 870.1 series control boxes are not directly interchangeable with earlier and existing models, TT'G 760-1, MMI 810, MMG 810 and must therefore not be used as field replacements for these types.

TECHNICAL SPECIFICATION

1. Electrical

Supply:	240V (+10%, -15%) 50 Hz (50 – 60 Hz)
Supply variations:	Timings will vary in proportion to the supply frequency.
Max. Fuse rating:	10A (rapid) 6A (slow)
Power consumption:	10 VA
Max. output current per terminal:	
- Kl.3	2 A, cos ϕ 0.2
- Kl. 4, B	2 A, cos ϕ 0.4
- Kl. 6, C	1 A, cos ϕ 0.4
Total output current:	5 A, cos ϕ 0.4
Air pressure proving switch contacts:	5 A rating at 240V, reaction time better than 5 seconds.
Flame detection system:	Flame Ionisation or U-V
Min. flame signal current:	1.0 μ A Ion, 5.0 μ A U-V
Typical flame signal current: Ionisation	10 μ A...15 μ A
U-V	15 μ A...20 μ A
Insulation standard:	P44

2. Timings

Waiting time at start :	9 secs approx.
Pre-purge time:	65 secs
Ignition safety time:	Nil Ignition safety
time ts1:	5 secs. max.
Delay time to main flame:	10 secs. approx.
Reaction to loss of flame:	Less than 1.0 sec.
Reset time from lockout:	None

3. General

Ambient temperature rating, control box & UVZ 780	-20 ... +60 C all models.
Flame detector probe:	Heat resisting metal, well insulated. (Material and insulation as for an ignition electrode)
Insulation resistance for Max. cable to flame detector	not less than 50M Ω
Weight control box + base:	20m
Wiring base type	0.35 kg
Mounting attitude:	S 701/TTGF/FN
	Any

Special Note: If at any time this product requires to be repaired, such repair should only be carried out by Satronic or their nominated Agent. It should not be repaired by unauthorised repairing agencies or companies.

