

# FAY

## FM F MODELS (FM F50- FM F65) SEISMIC ACTUATED AUTOMATIC GAS SHUT OFF VALVE (MECHANICAL EARTHQUAKE VALVE) USERGUIDE

### DESCRIPTION

This device is designed to automatically cut the gas flow under earthquake effects in accordance with the TS12884 standard conditions. When the device is exposed to seismic vibration at acceleration range given in the standard conditions, it makes the desired closure. The factory settings are made accordingly and are made available to the users in this way. The settings cannot be changed. It cannot be expected to work at different values. When the device is shut, it is not installed automatically and does not allow gas flow. The device is re-installed by pulling the handle and then the gas flow is provided.

### TECHNICAL SPECIFICATIONS

- \* Working Pressure: 0-501 mbar and 0-4 bar
- \* Operating Temperature: -23 ° C / + 60 ° C
- \* The gases that can be used: Natural gas, LPG, Methane, Propane, Air, etc., gaseous fluids.
- \* Aluminium Body, inner parts are brass and stainless steel.

### INSTALLATION INSTRUCTIONS

- The installation must be performed by the fitter authorized by the gas distribution company.
- The device should be installed to detect seismic activity in the building, yet not to detect the movement caused by the dynamic response of structures or equipment.
- The pipes must be cleaned before installation.
- The gas flow direction for FDV32 / FDV40 / FDV50 / FDV65 / FDV80 / FDV100 device models should be installed in a vertical position in the direction of the arrows locating the scale at the top.
- You must pay attention to levelled installation. Otherwise, your device can lead to unwanted gas cuts due to early closing.
- The device is connected to the building on the main line with 2 clamps on the input and output. The following first clamp should be mounted max 1m away from the device. The standard practice is performed in the next clamps.
- The distance from the clamps to the record or device should be max 150mm.
- The clamps may be outside of the box.
- After mounting the device on balance, the box should be installed.

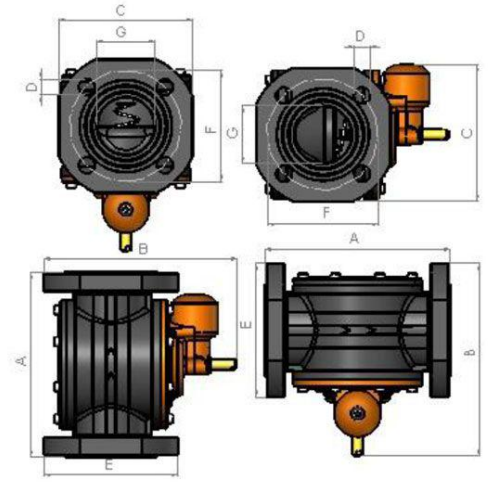

MODEL	DN	Size	Working Position	Max. Working Pressure	DIMENSIONS						
					A	B	C	D	E	F	G
FMF 500	50	2"	Vertical	501 mbar	208	216	150	18	150	124	65
FMF 501	50	2"	Horizontal	501 mbar	208	216	153	18	150	124	65
FMF 502	50	2"	Vertical	4 bar	208	216	150	18	150	124	65
FMF 503	50	2"	Horizontal	4 bar	208	216	153	18	150	124	65
FMF 650	65	2 1/2"	Vertical	501 mbar	208	216	150	18	150	145	65
FMF 651	65	2 1/2"	Horizontal	501 mbar	208	216	153	18	150	145	65
FMF 652	65	2 1/2"	Vertical	4 bar	208	216	150	18	150	145	65
FMF 653	65	2 1/2"	Horizontal	4 bar	208	216	153	18	150	145	65

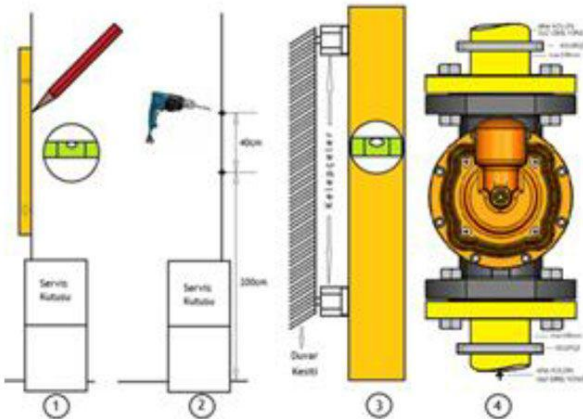

VERTICAL INSTALLATION

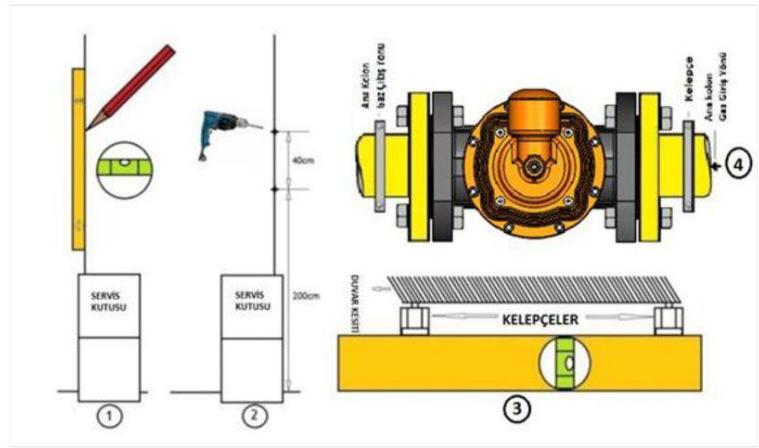

HORIZONTAL INSTALLATION

### SET-UP

After the installation of the device in balance and in its box, insert the setup lever button to the setup shaft. Wait for 5 seconds after pulling it. So, your device is in installed condition.

- Remove the setup lever from the shaft and screw the reverse to the body of the device.
- When you do that, your device will be maintained once again and its lifetime is extended.

### RE-INSTALLATION - RESET INSTRUCTIONS

- Notify the authority in the event of an earthquake when the gas is cut due to the activated device.
- The device can be re-installed by the firms authorized by the gas distribution company.
- The authorized people can open the gas checking whether the gas line leaks in your building.

To do this: help the authorities in the following matters.

1. Turn off the devices connected to gas in all apartments,
2. Turn off the gas valves in the apartment entrances,
3. Turn off the main column valve located before the earthquake valve,
4. Please note that there should be no cracks and breakage in the pipelines of the main column and internal installations.

**WARNING: IN CASE OF THE FAILURE OF THE DEVICE, THE AUTHORIZED PERSONS MAY REMOVE IT FROM THE GAS PIPELINE. NEVER MAKE ANY INTERVENTION ON THE DEVICE. THE MODIFICATIONS ON THE DEVICE AND THE LIABILITIES ARISING FROM THIS DO NOT BIND THE MANUFACTURER. THE DEVICE MODIFIED IN ANY WAY IS EXEMPT FROM THE WARRANTY. IT IS PRICED WHEN BROUGHT TO THE SERVICE.**

### SPARE PARTS AND SERVICE STATIONS

- In all of your problems related to the product, you can contact our Central Service or our factories for detailed technical information. [www.faymakine.com.tr](http://www.faymakine.com.tr)

### INSTRUCTIONS FOR THE BOX TO BE USED

- The device must be taken into a box to prevent intervention from unauthorized persons.
  - The sizes of the box should be larger than the size of the valve.
  - There should not be a barrier to prevent access to the setup lever of the device.
  - The box should protect the device from external impacts, dust and water and constant sunshine.
- The device does not require any maintenance. There should be absolutely no maintenance or intervention to the device and the connected column line by the user whatever the reason may be. The authorities should be informed in case of failure. All the repairs should be performed by the central service. The defective device should be removed and displaced by the authorized company and sent to the Central Service. After making sure that there is no pressured gas in the column line, the device should be removed by authorized persons for the repair or replacement of the device. Make sure the device was previously used and the gas valves are cut; otherwise shut it down. Always use the proper seal before mounting the device to the column line after the repair. Make sure the device connections do not leak after the repair. In case of the re-installment of the device, it should be checked. If it is not balanced, the authorized fitter or the authorized gas distribution company.

### MATTERS TO BE CONSIDERED AND WARNINGS

The device must be installed by an authorized fitter. The installation of the device must be carried out in full scale. This device must be installed by authorized installers according to the manufacturer's installation guidelines. After the device cuts the gas flow, only the authorized persons should check the gas leakage and setup the device once again. The working pressure indicated on the technical characteristics should not be exceeded and the product should not be given more pressure than the maximum working pressure stated on the product. There should be no intervention on the device, and the repairs should not be made by unauthorized persons. Do not tamper with the device, the covers of the device should not be opened. No wires, water etc. should be allowed in the device. The device should not be left on the ground. No mud, stones, etc. should enter the device. The sealing components such as linen, teflon etc. used in the pipe valve connection should be prevented from entering the device during the setup process or sealing chemical should be used. Otherwise, the device may not operate in the prescribed manner.

### FAILURE CAUSES AND CONSEQUENCES

The failure can be in three parts. Please contact our service centres in all failure cases.

1. The failures that may occur during the production and shipping of the device to the end-user: the products should not be thrown during the transport and shipping, there should be no shaking due to impact. No heavy load should be placed on top and should not be left on wet surfaces. The device should be checked for failures before connecting to the column line. The instalment is checked. The damages on the device body and connections are checked. In case of any failures, the device is sent to the central service. The central service is expected to respond. The service decides whether it is under the warranty scope.
2. The failures related to the device tampering: In case of any failure due to tampering, it is not covered by the warranty anymore. Do not connect the dismantled devices to the line again. You may have damaged the internal components since the device is sealed in a way that cannot be opened.
3. The failures due to external causes after the device is connected to the gas pipeline: Ensure the accuracy of the mounting direction. In cases of failure, notify the authorized fitter or gas distribution companies. The end users should not interfere with the device. The setup lever is attached to the shaft during assembly. Pull it by hand, wait for 5 seconds and release the setup lever. If it does not work, try again. Screw the setup button in reverse to the device. If the product is not installed, the device is defective. While there is gas in the column line, if it is closed due to a reason outside the seismic movement or if the setup lever is closed, promptly notify the authorized gas distribution company. The device may have been off due to impact on the column line.

It is the mechanical earthquake valve sensing the seismic (earthquake) motion and as a result automatically closing the gas flow where gas is used which can then be re-installed manually, and remains in the closed position until the installation, but normally is in the open position.

The device automatically turns off the gas flow without leakage thanks to the gas cutting equipment as a result of detecting movements when the seismic activity occurs at the acceleration and frequency values depending on TS 12884 standards. Whether the seismic activity continues or not, the gas flow will remain closed until the device is manually re-installed. The gas cutting mechanisms of the device are protected against intervention and tampering by unauthorized persons. All the parts of the product are designed and produced in a way to ensure the prescribed safety, durability and durability properties. The SENSOR COVER IS NON-DETACHABLY AFFIXED to protect the factory settings. Detaching it will violate the WARRANTY conditions, and will damage the device. In order to prevent damage by the gas flow to the device components and storage, the device is resistant against sulphur compounds, corrosion, natural gas, sunlight, moisture, and temperature changes. All materials used in the construction of the exterior of the device is resistant to prolonged exposure to freezing cold and moisture, dirt, ozone, fertilization, mineral oils, vegetable oils, grease, and sunlight for a long time. In case of failure, send the device to the central service. If the failure is covered by the warranty, no fee will be demanded. In the conditions resulting from the user,

## WARRANTY CONDITIONS

1. The ministry stated warranty period starts from the date of delivery and is for 5 years.
2. The entire product including all parts is under warranty of our company.
3. In the event of a failure within the warranty period, the repair time will be added to the warranty time.
4. The repair time will not exceed 20 business days.

5. In case of failure of the product within the duration of the guarantee due to the material and labour or the installation, no charges will be demanded under any label such as the labour costs, the cost of replaced parts etc.
6. From the date of delivery to the consumer, as long as it stays within the specified warranty period, within one year; if the failure exceeds six times within the warranty period determined by manufacturer-producer and / or importers and if these failures perpetuate the inability to benefit from the device, if the maximum period for repair is exceeded, if the company's service stations do not exist, if it is determined that the device cannot be repaired in the report to be issued by respectively the vendor, dealers, agency representative, or importer or manufacturers, the consumer may demand the free replacement of the goods, the refund of the price or price reduction in the percentage of the defect.
7. The failures resulting from the use of the goods contrary to the matters in this manual are out of warranty. For the problems that may arise in connection with the guarantee document, you can consult the Customs Department of Commerce General Directorate for Consumer Protection and Market Surveillance; and for the objections or complaints you may refer to the consumer courts and consumer arbitration .

**FAY MEKANİK MAKİNE SAN. Ve Tic. LTD.ŞTİ.** Centre–Central Service  
Address:KüçükcamlıcaMah. GülerSok. NO:1 /B Üsküdar 34696 /İSTANBUL  
Phone: 0(216) 660 0 777Fax: 0(216) 660 0 772[www.faymakine.com.tr](http://www.faymakine.com.tr)