



1. WORKING PRINCIPLE





Working principle for the metering body

The M series meter is positive displacement meter for liquids. They are designed for liquid metering both in transfer and process control applications. Because of their design they are easy to keep and can suit a wide range of applications. The meter consists of housing where two bladed displacement rotors and a central single blocking rotor turn in a synchronized relationship within three cylindrical bores with no metal-to-metal contact within the meter element. Each rotor is supported on either end by a bearing plate through which the rotor shafts protrude.

The bladed displacement rotors alternately move through the two half-cylinder bores of the meter element, while the single blocking rotor rotates within its bore in such a way as to produce a continuous capillary seal between the unmeasured upstream product and the metered, downstream product.

At one end of each rotor shaft there is a timing gear. The blocking rotor gear, having twice the number of teeth of each of the displacement rotor gears, rotates at half the RPM of the displacement rotors.

2. MODELS & ACCESSORIES







PICTURE	DESCRIPTION	MODELS
	<p>meter with mechanical register</p>	<p>M-40-A 1.5" M-50-A 2" M-80-A 3" M-100-A 4" M-150-A 6"</p>
	<p>Meter with Mechanical Register, Air eliminator And Strainer</p>	<p>M-40 1.5" M-50 2" M-80 3" M-100 4" M-150 6"</p>
	<p>Meter with mechanical, preset register, preset valve, air eliminator and Strainer</p>	<p>M-40-PRE 1.5" M-50- PRE 2" M-80- PRE 3" M-100- PRE 4"</p>
	<p>Meter with mechanical printer register, preset register, preset valve, air eliminator and Strainer</p>	<p>M-40- PRE PRIN 1.5" M-50- PRE PRIN 2" M-80- PRE PRIN 3" M-100- PRE PRIN 4"</p>

MAINTENANCE MANUAL FOR M SERIES FLOW METERS (ALUMINIUM)



PICTURE	DESCRIPTION	MODELS
	<p>M-50-LPG Meter, 2" Completely Set With Mechanical Register, different valve, Air eliminator and Strainer For LPG</p>	

ACCESSORIES

		<p>6" Strainer +FL air eliminator</p>						
		<p>2" Different Valve for LPG</p>						
		<p>FL Air Eliminator (Aluminum)</p>						
		<table border="1"> <tr> <td data-bbox="675 1489 1063 1547">Strainer(Aluminum)</td> <td data-bbox="1063 1489 1464 1547">50 2"</td> </tr> <tr> <td data-bbox="675 1547 1063 1628"></td> <td data-bbox="1063 1547 1464 1628">80 3"</td> </tr> <tr> <td data-bbox="675 1628 1063 1686"></td> <td data-bbox="1063 1628 1464 1686">100, 4"</td> </tr> </table>	Strainer(Aluminum)	50 2"		80 3"		100, 4"
Strainer(Aluminum)	50 2"							
	80 3"							
	100, 4"							
		<table border="1"> <tr> <td data-bbox="675 1686 1063 1767">piston valve</td> <td data-bbox="1063 1686 1464 1767">V-50</td> </tr> <tr> <td data-bbox="675 1767 1063 1848"></td> <td data-bbox="1063 1767 1464 1848">V-80</td> </tr> <tr> <td data-bbox="675 1848 1063 1906"></td> <td data-bbox="1063 1848 1464 1906">V-100</td> </tr> </table>	piston valve	V-50		V-80		V-100
piston valve	V-50							
	V-80							
	V-100							
		<table border="1"> <tr> <td data-bbox="675 1906 1063 1986">check valve</td> <td data-bbox="1063 1906 1464 1986">50</td> </tr> <tr> <td data-bbox="675 1986 1063 2060"></td> <td data-bbox="1063 1986 1464 2060">80</td> </tr> </table>	check valve	50		80		
check valve	50							
	80							

MAINTENANCE MANUAL FOR M SERIES FLOW METERS (ALUMINIUM)



MECHANICAL&ELECTRONIC REGISTER

PHOTO	DESCRIPTION
	Mechanical Register
	Preset Register
	Mechanical counter with ticket printer
	GK-7 Own consumption controller Code 25130-CF00000
	GE · Electronic display with litre preset code 253400200
	Pulser
	Gear Plate



www.inergy.ir

MAINTENANCE MANUAL FOR M SERIES FLOW METERS (ALUMINIUM)



Technical Data:

Model	M-40	M-50	M-80	M-100	M-150
Size	40 mm / 1½"	50 mm / 2"	80 mm / 3"	100 mm / 4"	150 mm / 6" or 100 mm / 4" (for option)
Flow range (l/min)	25-250	55-550	115-1,150	170-1,700	300-3,000
Volume per revolution	0.309 L	0.681 L	1.839 L	5.102 L	9.507 L
Max. pressure	10 bar				
Accuracy	±0.2 %				
Repeatability	≤ 0.07 %				
ATEX Category	II 2G				
Protection Mode or own supply	Ex h IIB T5 Gb				
Standard Measurement	Litre / US Gallon / IMP Gallon (please ask for it when ordering)				
Dimension (mm)	510x460x490	510x460x490	580x500x610	760x640x720	800x650x790
Net Weight (kg)	23	26	40 kg	70 kg	130 kg
Gross Weight (kg)	25	28	47 kg	93 kg	180 kg

3. TYPICAL APPLICATION:

- Check of loading/unloading operations of fuel and petrochemical products in fuel bulk plants and/or refineries
- On truck tanker for fuel/LPG transport and delivery
- Heavy duty fuel dispensing system for big vehicles and airplanes

Typical Application of Aluminium Construction

Class 1 meter: refined petroleum products, such as gasoline, fuel oil, diesel fuel, kerosene, ethylene glycol, motor oils and rotogravure ink.

Class 2 meter: aviation gasoline and jet fuels.

Class 3 meter : a wide variety of products such as: liquid sugars, corn syrup, corn sweeteners, dextrose, fructose, sucrose, maltose, Lactose, corn oil, soy bean oil, cotton seed oil, coconut oil, and shortening's etc. rate of flow is based on viscosity to pressure loss relationship.

Class 10 meter: liquefied petroleum gas (LPG) including butane, isobutene, pentane, ethane, Freon and propane.

Class 14 meter: crude oil, also for heated and/or viscous liquids including animal fats, resins, #6 oil and non-abrasive asphalt emulsions.

Class 15 meter: for metering oil or water based latex products, polyester resins, and adhesives (neutral pH). Also available for metering herbicides and nitrogen fertilizer solutions (requires Viton and Teflon seals).

Class 16 meter: for general solvent metering, such as methanol, toluene, xylem, naphtha, acetone, MEK, MIBK, and alcohols including ethanol.

4. INSTALLATION REQUIREMENT

- Make sure you observed all the safety rules concerning room ventilation, temperature control, fire prevention and fire extinguishing systems
- Make all connections in order to ensure the meter and grounding device system are equipotential.
- Make sure you can get easily to fire extinguishers for your product. Consult your local fire department for proper information about fire problems and mandatory law dispositions
- Install the meter and its accessories complying with the electric and safety standards in force.
- Prior to meter installation the entire piping system must be flushed, with a liquid that is compatible with the construction of the meter.
- Keep the meter external surfaces clean in order to notice easily possible defects.
- The meter must be firmly fastened to a platform or other support regardless of its mounting position. Never hand the meter to the piping system and do all necessary to avoid that piping tensions due to such cases as material dilation by temperature, stress of flange screw, etc. Are conveyed to the meter assembly. Expansion joints both at the inlet and outlet of the meter assembly will prevent it from these tensions.
- Calculate suitable working areas for maintenance operations. Remember you need a support where to mount the meter.
- Meters are designed with special materials depending on the liquid/s they are used. Their compatibility with a certain class of liquids is indicated on the M series tag. Meters should not be used with other liquids. In case of doubt please apply to M series for information.
- If required, convey the piping downstream of the meter towards a bank prover in order to carry out calibration and/or metrological check.
- When missing in the assembly install a suitable strainer upstream of the meter so as to strain every foreign material (welding dross, dirt etc.) Foreign bodies over a certain size could get into the rotors and cause them to seize.
- When the meter assembly has got an air eliminator you have to connect the two outlet threaded ports (or just one when the assembly includes an air check valve) to the tank of the liquid which is metered or to other sealed container under ambient pressure. This is to avoid contamination of the surrounding.
- There is a mutual relationship between the liquid flow direction in the meter and the correct indication of the delivered quantity on the register display; if you desire the register to count down, you will have to reverse the position of the adjuster drive gear.
- New or repaired piping can be the source of welding dross or foreign material which clog or break the strainer network. The strainer basket must be daily checked during the first 100 hours of operation.
- A frequent check and cleaning of the strainer are required in order to get a good performance. Locate the strainer on the inlet side of the meter. Screw the strainer firmly to the meter flange. Fasten the piping to the strainer
- The meter and its accessories must not support the weight of piping system. There is enough room to remove the air eliminator.
- Locate the air eliminator on the inlet side of the meter. Always mount the air eliminator in vertical position. Screw the air eliminator to the coupling flange of the strainer. Connect and fasten the piping to the air eliminator.

5. OPERATION REQUIREMENTS

- The meter must remain full of product at all times. An easy way to accomplish this is to put the meter assembly in the line below the piping centre-line. This requires adding elbows and flanges prior to installing the meter. The meter should be installed in a bypass loop, below the pipe centre-line, with block valves upstream and downstream. A block valve should be located in the mainstream, labelled as the bypass valve. Mounting the meter like this allows to keep the meter always full of liquid and to isolate it for servicing or calibration when required, while continuing flow through the bypass-valve.
- Attention: every part of the piping which could stop and/or isolate the flow should be provided with a pressure relief to prevent damages from thermal expansion.
- Upstream lines must be maintained full to prevent air from entering the meter. If the upstream or inlet lines are constructed in a manner which allows reverse flow, foot valves or back checks must be installed
- Underground tanks that are furnished with a submersible pump will eliminate many problems that occur with positive displacement pumps (suction pumps) when suction piping is incorrectly sized or when the lift is too great.
- Give careful attention to your system's pumping equipment and piping because of their influence on liquid being measured as it enters the meter assembly. Systems should be made free of conditions that cause or introduce entrained air or vapour
- Follow the manufacturer's recommendation fully when installing pumps. Give particular attention to factors like: use of foot valve, pipe size to the inlet and conformance to net positive suction head conditions when suction pumping is required.
- For volatile liquids, such as light hydrocarbons which tend to flash or vaporize easily at higher ambient temperatures, it is desirable to use flooded suction and piping sized large than the normal pump size.
- When locating the meter under a tank (on truck tankers) the course of the suction piping affects metering precision. The piping should have a constant inclination towards the pump avoid goosenecks
- Hydraulic shock is harmful to all components of an operating system including valves, pump and the meter. In particular meters must be afforded protection from shock because of their need to measure with high precision. Generally the best protection is prevention, which can be readily accomplished by adjusting valve closing rates in such a manner that shock does not occur.
- Thermal expansion like hydraulic shock is a phenomenon that can easily damage meters and systems in general. Care should be taken in designing the system to include pressure relief valves in any portion or branch of the system that might be closed off by closure of operating valve or block valves.
- The meter can operate in a dry condition (with no liquid) for no longer than 5 minutes
- The meter shall operate within the recommend flow rate range. Only in some exceptional events it may be allowed to let it work with a 20% higher flow rate than the nominal one and only for a short time.
- Start up during the starting up the system shall be slowly filled in with liquid. There shall be no air in this phase. Take care not to damage the meter. The system should be filled in by gravity or by using a pump.
- Filling in the system by means of a pump. Apply to the pump manufacturer for information about its loading. After the pump has been loaded with liquid, operate as follows:
Make sure the downstream valve is shut down;
The meter counter will start turning;
When the meter has started counting volume, open completely the valve;
In this phase the meter should not run faster than 20% of its rated flow. Once the product is flowing out the end of your system, the outlet valve can be opened all the way provided that the system is designed not to exceed the flow rate marked on the meter



www.inergy.ir

MAINTENANCE MANUAL FOR M SERIES FLOW METERS (ALUMINIUM)



- Never use the meter or the system when they are not completely full of liquid or in presence of air bubbles or compressed air / vapour. If this is not possible you require devices to eliminate air/ vapour.

5.1. Calibration

1. REMOVE THE DUST COVER

- Cut the dust cover seal wire with side cutters.
- Remove the dust cover screws.
- Remove the dust cover

2. SET THE STANDARD ADJUSTER:

- Check meter registration by delivering product to reliable, accurate prover. Perform multiple delivery tests to verify the meter repeatability.
- Record the setting indicated on the adjuster.
- Note the difference between the volume of the prover and the volume indicated on the meter counter. Calculate the % correction required using the formula below:

$$\% \text{ Correction} = \frac{\text{Volume in prover} - \text{Volume on meter counter}}{\text{Volume in prover}} \times 100$$

- Loosen the adjuster clamp screw.
- When the prover volume is less than the meter counter volume, add the percentage to the original adjuster setting by turning the thimble towards the arrow marked larger (volume). Correct the original setting by approaching the number desired from the next larger number. For example, if the desired adjuster setting is 2.4, turn the adjuster thimble to the left to number 5, then to the right to obtain the 2.4 setting. Adjuster is currently set at 2.3 in the right drawing.
- When the prover volume is more than the meter counter volume, subtract the percentage from the original adjuster setting by turning the thimble in the direction of the arrow marked smaller volume percent.
- Retighten the adjuster clamp screw. Run product through the meter to allow the adjuster to take a set. Then make several prover runs to check for accuracy.

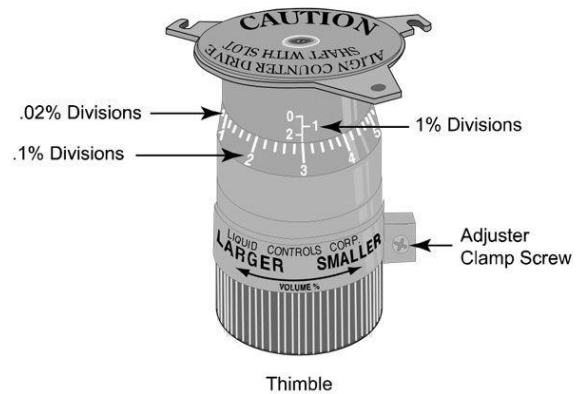
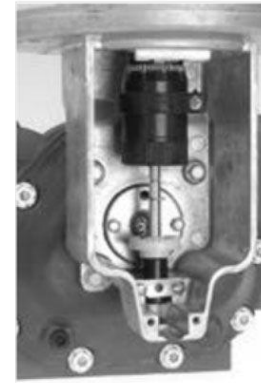

6. TROUBLESHOOTING

ITEM	TROUBLE	CAUSE AND SOLUTION
1	Leakage from the lid seal	- The seal has been damaged by pressure or bolts have been screwed incorrectly.
2	The product flows through the meter, but it is not counted by the register.	A. Check the packing glands and gears. B. If all parts work properly, the problem is to be found in the register which is defective and should be checked and repaired.
3	Gear cogs are broken.	- Sharp flow variations
4	The product flows through the meter, but the register does not work correctly.	A. The register has not been adjusted correctly. B. Wrong gear plate ratio or wrong installation of a gear on the plane
5	The meter operates slowly.	- The internal valve gear is defective. The valve does not open correctly.
6	The blocking and displacement rotors do not turn.	A. Breaking of the strainer basket likely due to improper maintenance. Replace the strainer basket and follow maintenance procedures. Clean out the meter and its parts. B. The gasket got dented so as to cause leaks which allow the intrusion of strange bodies. Replace the gasket. C. Blocking and displacement rotor are blocked. Call the technical service.
7	Leak of the product from the strainer lid	A. The trouble may be due to seals which are damaged or worn out. Replace the seals. If they are Teflon made, replace them even if still in a good condition. B. Dirty surfaces which prevent a perfect sealing by the gaskets. Clean out the gasket housings.
8	Pressure drop in the strainer or flow decrease in the meter	A. The basket network is clogged by intruded material. Clean out the strainer body and basket. B. The basket network size does not fit the liquid viscosity. Replace the basket with a new one having a proper net size (thicker or looser, with more or less "meshes").
9	The floater in the air eliminator is crushed.	The crushing is due to water hammers, the floater is always in position of open slots, letting the liquid leak from them or in the position of closed slots, letting air and vapour go through the meter. Beware water hammers and replace the floater.
10	The floater in the air eliminator is punctured.	As time goes by the floater can get punctured and fill with product when operating, so that it gets heavy and remains in the position of open slots. This causes the product to leak from the slots. Replace the floater.
11	The reeds in the air eliminator are worn out.	There is not a perfect sealing with the slots. This cause the product to leak. Replace the reeds.
12	The product leaks from the air eliminator lids.	The gaskets or the rubber coated plates are worn out. Replace the plates or the gaskets.



www.inergy.ir

MAINTENANCE MANUAL FOR M SERIES FLOW METERS (ALUMINIUM)



7. WARRANTY

1. All the products manufactured by TOT COMERCIAL SA have a WARRANTY of 12 (twelve) months from their purchase, against any manufacturing defect.
2. TOT COMERCIAL SA guarantees, in the warranty period, the change/the devolution of the defective part or product. This material must be sent with prepaid freight to our factory, or any appointed technical service. After our technical inspection, it will be determined whether the responsibility is from the manufacturer, the user, the installer, or the delivery transport.
3. The warranty does not cover: the inadequate use, the negligence, the corrosion, the abuse, the manipulation, or the wrong installation of the products, the use of non-original spare parts or not concerning to the specific model. All the manufactured and/or commercialized equipment must be installed according to the manufacturer's instructions.
4. The accessories and the products not manufactured by TOT COMERCIAL SA are liable for their original manufacturer's warranty.
5. Because of the constant innovations and development, TOT COMERCIAL SA reserves the right to modify the specifications of its products and publicity, without prior notification.

TOT comercial, s.a.



www.inergy.ir

MAINTENANCE MANUAL FOR M SERIES FLOW METERS (ALUMINIUM)



8. EU DECLARATION OF CONFORMITY

Manufacturer:

TOT COMERCIAL, S.A.
Partida Horta d'Amunt s/n - Apartado Correos nº 149
25600 BALAGUER (Lleida) · SPAIN

STATES:

Under its own responsibility that the supplied product:

HIGH FLOW METER

Mark: **GESPASA**

Model: **M SERIES**

is in accordance with the following legislative and/or normative documents:

DIRECTIVE	No. and date of rules
2006/42/CE: on machine safety 2014/34/UE: relating to equipment and protective systems intended for use in potentially explosive atmospheres	EN-ISO 12100:2012

In compliance with the European Directive 2014/34 / EU, TOT COMERCIAL SA has deposited the technical documentation provided for in Annex VIII, point 2 of said Directive in the Notified Body No. 0080

INERIS nr. 036704/21 · Park Technologique Alata - BP2 60550 VERNEUIL-EN-HALATTE (France).

- The pumps, meters and nozzles as nearly machines must not be on service while the machine, where these are placed, has not been declared of conformity with the 2006/42/EC (Machines) Directive requirements.

- This Declaration will lose its validity in case that any modification is made without the explicit manufacturer's consent.

BALAGUER (Lleida), April 2023

Andreu Pané

9. DIMENSIONS

M-40-1 Meter Dimension

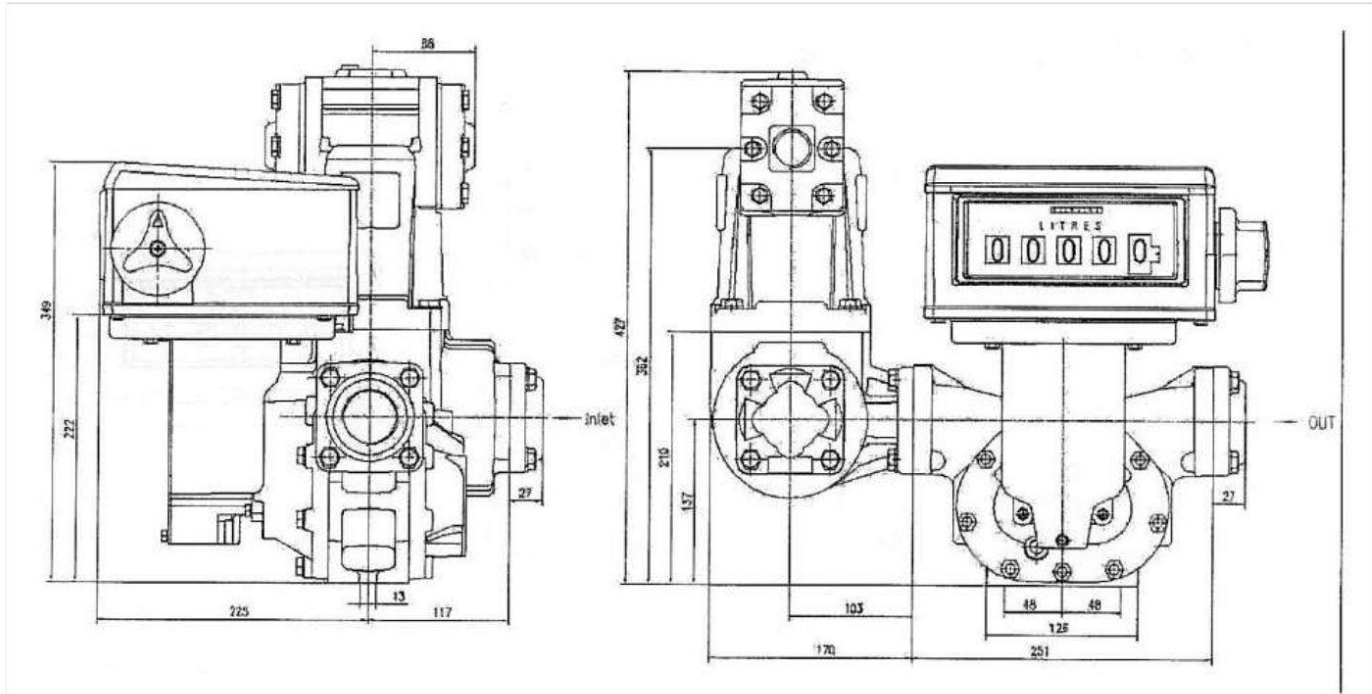

M-50-1 Meter Dimension

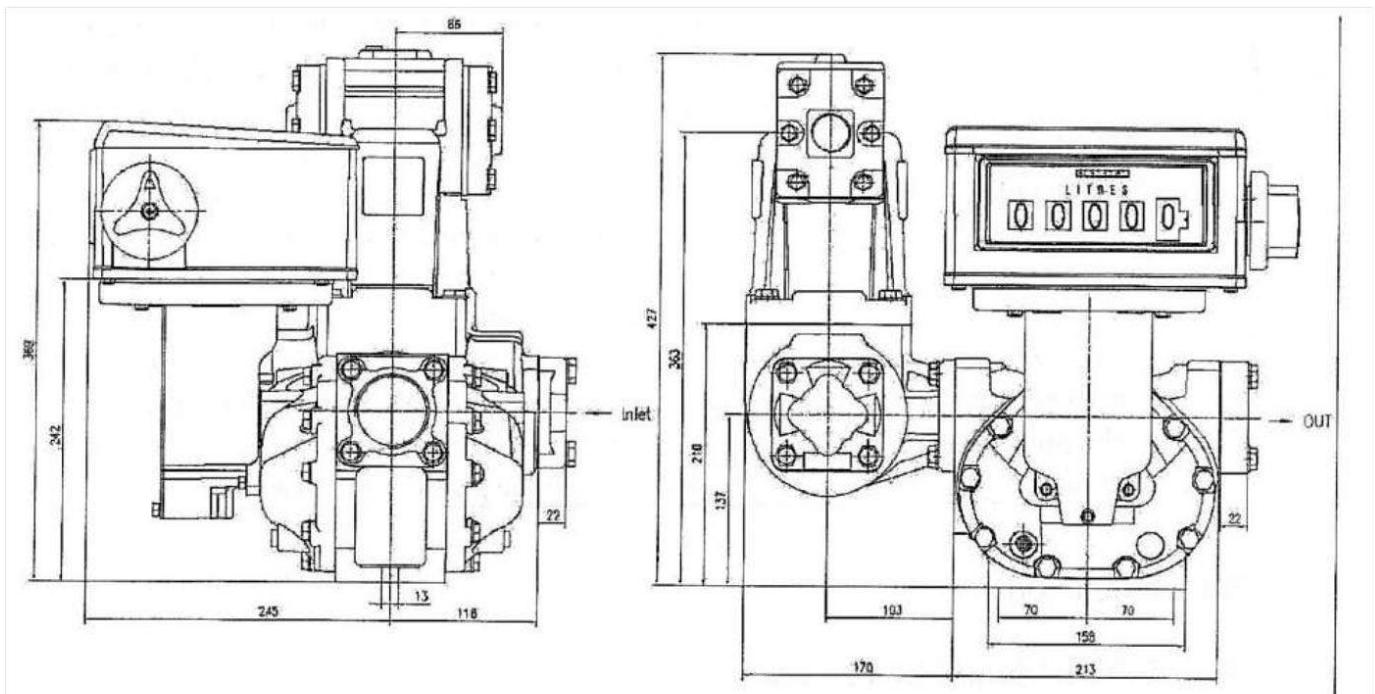

MAINTENANCE MANUAL FOR M SERIES FLOW METERS (ALUMINIUM)



M-80-1 Meter Dimension

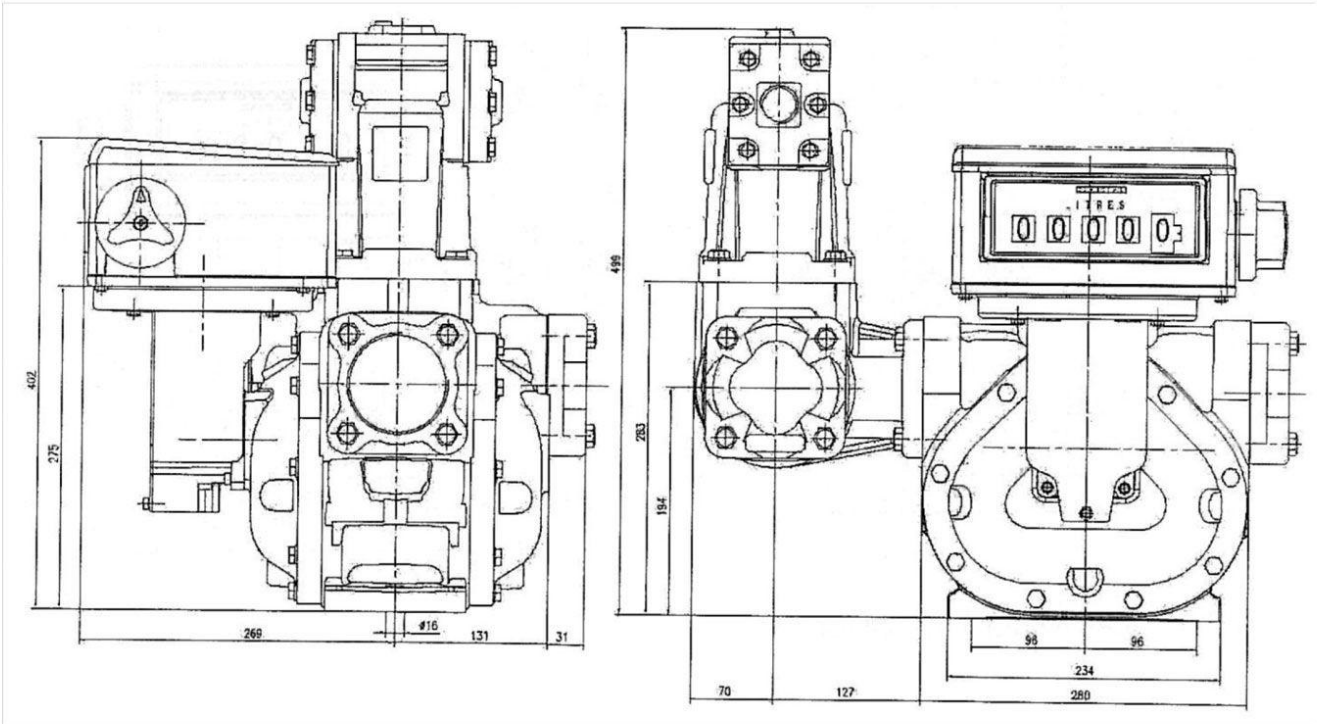

M-100-1 Meter Dimension

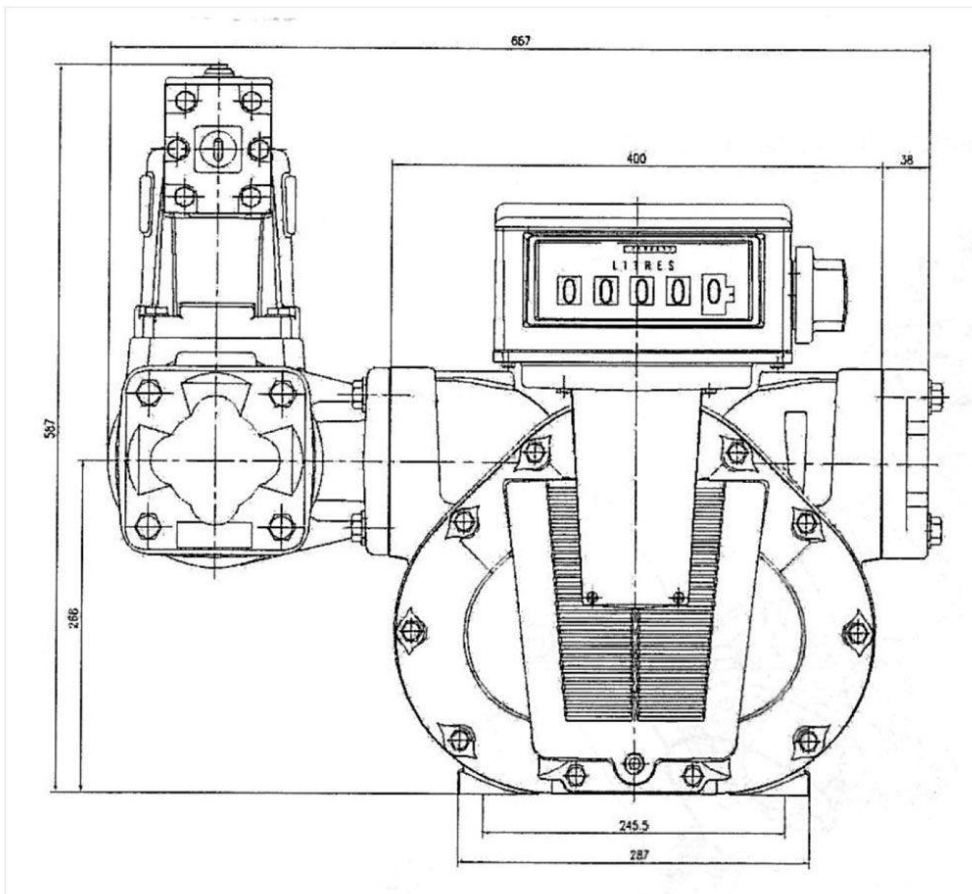

MAINTENANCE MANUAL FOR M SERIES FLOW METERS (ALUMINIUM)



M-150-1 Meter Dimension

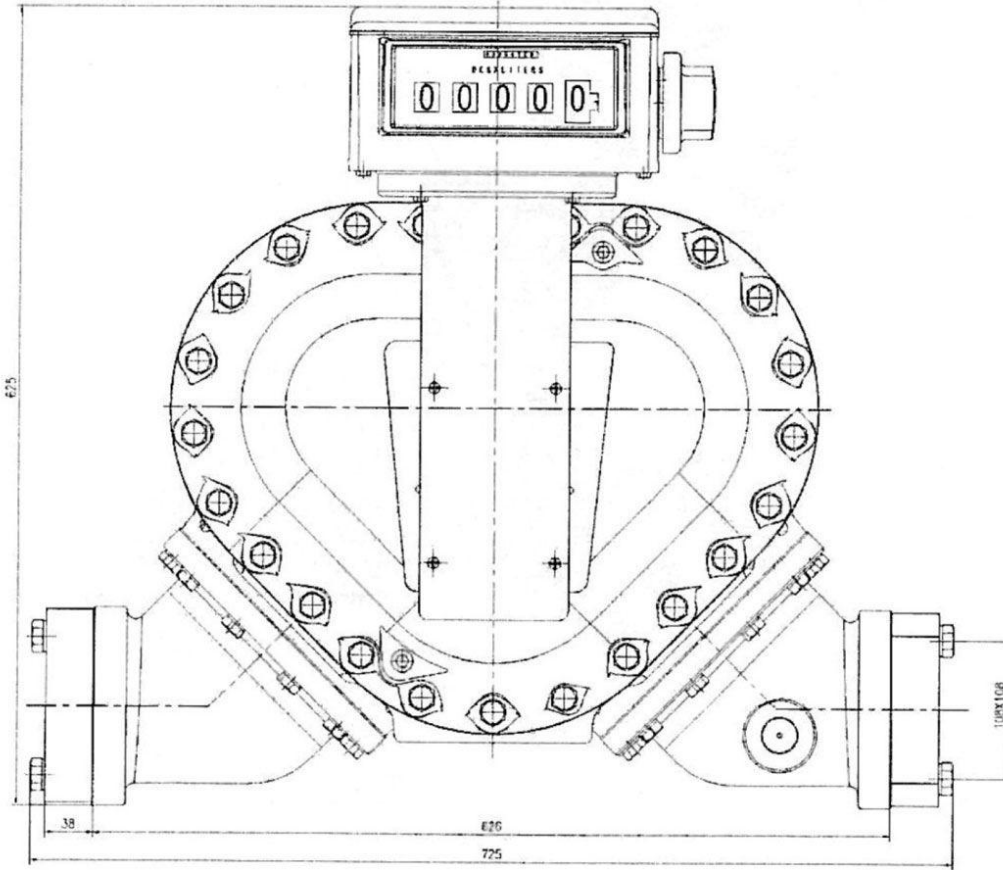

Spare Parts

10. EXPLOSION DRAWINGS OF METER

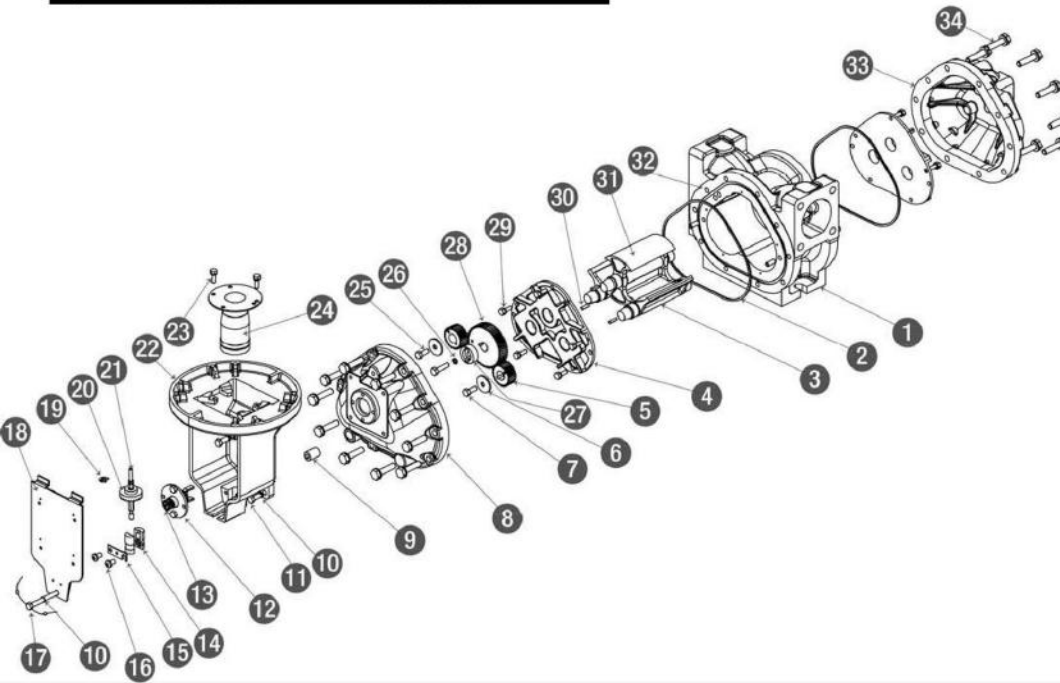

No.	DESCRIPTION
1	Housing
2	O-ring (2)
3	Displacement rotor assembly
4	Bearing plate
5	Gear displacement pinion (2)
6	Rotor gear washer (2)
7	Screw (2)
8	Front cover
9	Plug
10	Flat washer (5)
11	Screw (4)
12	Packing gland assembly
13	Packing gland gear
14	Drive shaft bushing
15	Bearing retainer
16	Screw (2)
17	Screw (1)
18	Dust cover plate
19	Retaining ring
20	Pinion gear
21	Shaft
22	Counter bracket
23	Screw (3)
24	Adjuster Assembly
25	Screw (1)
26	Lock washer
27	Driver packing gland
28	Blocking rotor gear
29	Screw (8)
30	Stainless steel key
31	Blocking rotor assembly
32	Pin dowel
33	Rear cover
34	Screw (20)

10.1. EXPLOSION DRAWINGS

Air eliminator / Eliminator de aire

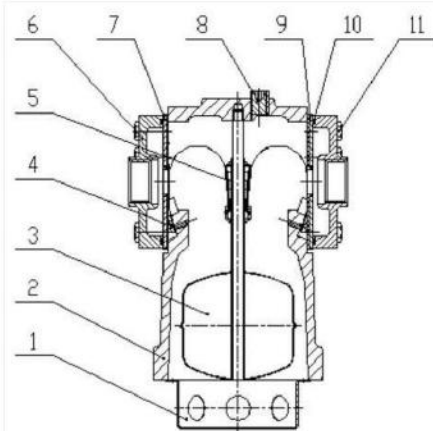

No.	Q.ty	DESCRIPTION / DESCRIPCIÓN	Class 1/16
01	1	Cup, Baffle / Copa	0506-01011
02	1	Housing / Carcasa	0501-01011
03	1	Float and Stop / Flotador y parada	0505-01011
04	2	Screw / Tornillo	0507-01011
05	2	Valve Reed / Reed válvula	0502-01011
06	2	Cover, Air elimination / Tapa - Eliminación aire	0508-01011
07	1	Valve Plate Assy / Montaje placa válvula	0503-01011
08	1	Plug / Tapón	0109-01011
09	1	Valve Plate ltd bleed/ Placa válvula	0510-01011
10	2	Seal ring, Outlet / Aro de cierre - salida	0509-01011
11	12	Screw / Tornillo	0504-01011

Strainer / Filtro

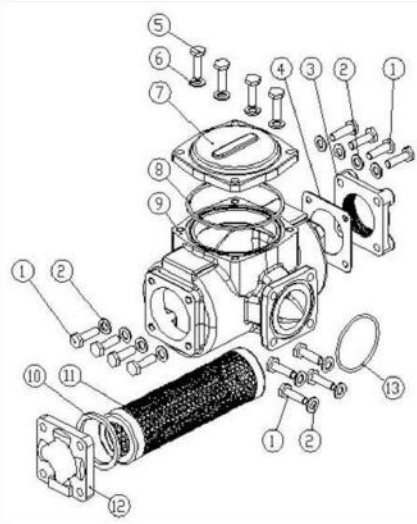

No.	Q.ty	DESCRIPTION / DESCRIPCIÓN	M-50	M-80
			Class 1	Class 1
01	12	Screw / Tornillo	0201-01011	0201-02011
02	12	Washer / Arandela	0202-01011	0202-02011
03	1	Flange / Brida	0203-01011	0203-02011
04	1	Flange Gasket / Junta brida	0204-01011	0204-02011
05	8	Screw / Tornillo	0205-01011	0205-02011
06	8	Washer / Arandela	0206-01011	0206-02011
07	1	Cover / Tapa	0207-01011	0207-02011
08	1	O-ring	0208-01011	0208-02011
09	1	Housing / Carcasa	0209-01011	0209-02011
10	1	Gasket / Junta	0210-01011	0210-02011
11	1	Strainer / Filtro	0211-01011	0211-02011
12	1	Cover / Tapa	0212-01011	0212-02011