

High-quality pressure transmitter For general industrial applications Model S-10



for further approvals
see page 6

Applications

- Machine building
- Hydraulics and pneumatics
- Pumps
- Chemical industry

Special features

- Measuring ranges from 0 ... 0.1 to 0 ... 1,000 bar [0 ... 5 psi to 0 ... 15,000 psi]
- Non-linearity 0.2 % of span (BFSL)
- Output signals: 4 ... 20 mA, DC 0 ... 10 V, DC 0 ... 5 V and others
- Electrical connections: Angular connector form A, circular connector M12 x 1, various cable outlets and others



Pressure transmitter model S-10

Description

The model S-10 pressure transmitter for general industrial applications is the ideal solution for customers with demanding measuring requirements. It features a very good accuracy, a robust design and an exceptional number of variants, meaning it can be suited to the widest range of applications.

Versatile

The model S-10 offers continuous measuring ranges between 0 ... 0.1 and 0 ... 1,000 bar [0 ... 5 psi and 0 ... 15,000 psi] in all the major units. These measuring ranges can be combined in almost any way with all the standard industry output signals, the most common international process connections and a wide number of electrical connections. Furthermore, it offers numerous options, such as different accuracy classes, extended temperature ranges and customer-specific pin assignments.

High quality

The robust design turns the model S-10 into a very high quality product, which even the most adverse environmental conditions cannot affect. Whether with the lowest temperatures when used outdoors, with extreme shock and vibration in machine building or with aggressive media in the chemical industry, this transmitter can meet all requirements.

Availability

All variants described in this data sheet are available on very short lead times. For particularly urgent demands, there is a sizeable stock available.

Measuring ranges

Gauge pressure								
bar	Measuring range	0 ... 0.1	0 ... 0.16	0 ... 0.25	0 ... 0.4	0 ... 0.6	0 ... 1	0 ... 1.6
	Overload safety	1	1.5	2	2	4	5	10
	Measuring range	0 ... 2.5	0 ... 4	0 ... 6	0 ... 10	0 ... 16	0 ... 25	0 ... 40
	Overload safety	10	17	35	35	80	50	80
	Measuring range	0 ... 60	0 ... 100	0 ... 160	0 ... 250	0 ... 400	0 ... 600	0 ... 1,000
	Overload safety	120	200	320	500	800	1,200	1,500
psi	Measuring range	0 ... 5	0 ... 10	0 ... 15	0 ... 20	0 ... 25	0 ... 30	0 ... 50
	Overload safety	29	29	72.5	145	145	145	240
	Measuring range	0 ... 60	0 ... 100	0 ... 150	0 ... 160	0 ... 170	0 ... 200	0 ... 250
	Overload safety	240	500	500	1,160	1,160	1,160	1,160
	Measuring range	0 ... 300	0 ... 400	0 ... 500	0 ... 600	0 ... 750	0 ... 800	0 ... 1,000
	Overload safety	1,160	1,160	1,160	1,160	1,740	1,740	1,740
	Measuring range	0 ... 1,500	0 ... 1,600	0 ... 2,000	0 ... 3,000	0 ... 4,000	0 ... 5,000	0 ... 6,000
	Overload safety	2,900	4,600	4,600	7,200	7,200	11,600	11,600
	Measuring range	0 ... 7,500	0 ... 8,000	0 ... 10,000	0 ... 15,000			
	Overload safety	17,400	17,400	17,400	21,700			

Absolute pressure								
bar	Measuring range	0 ... 0.25	0 ... 0.4	0 ... 0.6	0 ... 1	0 ... 1.6	0 ... 2.5	0 ... 4
	Overload safety	2	2	4	5	10	10	17
	Measuring range	0 ... 6	0 ... 10	0 ... 16	0 ... 25	0.8 ... 1.2		
	Overload safety	35	35	80	80	5		
psi	Measuring range	0 ... 15	0 ... 25	0 ... 50	0 ... 100	0 ... 250		
	Overload safety	72.5	145	240	500	1,160		

Vacuum and +/- measuring range						
bar	Measuring range	-0.6 ... 0	-0.4 ... 0	-0.25 ... 0	-0.16 ... 0	-0.1 ... 0
	Overload safety	4	2	2	1.5	1
	Measuring range	-1 ... 0	-1 ... +0.6	-1 ... +1.5	-1 ... +3	-1 ... +5
	Overload safety	5	10	10	17	35
	Measuring range	-1 ... +9	-1 ... +15	-1 ... +24		
	Overload safety	35	80	50		
psi	Measuring range	-15 inHg ... 0	-30 inHg ... 0	-30 inHg ... +15	-30 inHg ... +30	-30 inHg ... +60
	Overload safety	72.5	72.5	145	240	240
	Measuring range	-30 inHg ... +100	-30 inHg ... +160	-30 inHg ... +200	-30 inHg ... +300	
	Overload safety	500	1,160	1,160	1,160	

The given measuring ranges are also available in kg/cm² and MPa.
Other measuring ranges available on request.

Vacuum tightness

Yes

Output signals

Signal type	Signal
Current (2-wire)	4 ... 20 mA
	20 ... 4 mA
Current (3-wire)	0 ... 20 mA
Voltage (3-wire)	DC 0 ... 10 V
	DC 0 ... 5 V
	DC 1 ... 5 V
	DC 0.5 ... 4.5 V ratiometric

Other output signals on request.

Load in Ω

- Current output (2-wire):
 $\leq (\text{power supply} - 10 \text{ V}) / 0.02 \text{ A}$
- Current output (3-wire):
 $\leq (\text{power supply} - 3 \text{ V}) / 0.02 \text{ A}$
- Voltage output (3-wire):
> maximum output signal / 1 mA

Voltage supply

Power supply

The power supply depends on the selected output signal

- 4 ... 20 mA: DC 10 ... 30 V
- 20 ... 4 mA: DC 10 ... 30 V
- 0 ... 20 mA: DC 10 ... 30 V
- DC 0 ... 5 V: DC 10 ... 30 V
- DC 1 ... 5 V: DC 10 ... 30 V
- DC 0 ... 10 V: DC 14 ... 30 V
- DC 0.5 ... 4.5 V ratiometric: DC 4.5 ... 5.5 V

Reference conditions (per IEC 61298-1)

Temperature

15 ... 25 °C [59 ... 77 °F]

Atmospheric pressure

860 ... 1,060 mbar [86 ... 106 kPa/12.5 ... 15.4 psig]

Humidity

45 ... 75 % r. h.

Power supply

DC 24 V

Mounting position

Calibrated in vertical mounting position with pressure connection facing downwards.

Accuracy specifications

Non-linearity (per IEC 61298-2)

$\leq \pm 0.2 \%$ of span BFSL

Non-repeatability (per IEC 61298-2)

$\leq 0.1 \%$ of span

Accuracy at reference conditions

Including non-linearity, hysteresis, zero offset and end value deviation (corresponds to measured error per IEC 61298-2).

Accuracy

Standard	$\leq \pm 0.50 \%$ of span
Option	$\leq \pm 0.25 \%$ of span ¹⁾

1) Only for measuring ranges $\geq 0.25 \text{ bar}$ [$\geq 3.6 \text{ psi}$]

Adjustability of zero point and span

Adjustment is made using potentiometers inside the instrument.

- Zero point: $\pm 5 \%$
- Span: $\pm 5 \%$

Temperature error at 0 ... 80 °C [32 ... 176 °F]

- Mean temperature coefficient of zero point:
Measuring ranges $\leq 0.25 \text{ bar}$ [$\leq 3.6 \text{ psi}$]: $\leq 0.4 \%$ of span/10 K
Measuring ranges $> 0.25 \text{ bar}$ [$> 3.6 \text{ psi}$]: $\leq 0.2 \%$ of span/10 K
- Mean temperature coefficient of span:
 $\leq 0.2 \%$ of span/10 K

Long-term stability at reference conditions

$\leq \pm 0.2 \%$ of span/year

Time response

Settling time

- $\leq 1 \text{ ms}$
- $\leq 2 \text{ ms}$ for output signal DC 0.5...4.5 V ratiometric and measuring ranges $< 0.4 \text{ bar}$ [$< 5.8 \text{ psi}$]

Operating conditions

Ingress protection (per IEC 60529)

For ingress protections see "Electrical connections"

The stated ingress protection only applies when plugged in using mating connectors that have the appropriate ingress protection

Vibration resistance (per IEC 60068-2-6)

20 g

Shock resistance (per IEC 60068-2-27)

1,000 g (mechanical)

Permissible temperature ranges

	Standard	Option
Medium	-30 ... +100 °C [-22 ... +212 °F]	-40 ... +125 °C [-40 ... +257 °F]
Ambient	-20 ... +80 °C [-4 ... +176 °F]	-20 ... +80 °C [-4 ... +176 °F]
Storage	-40 ... +100 °C [-40 ... +212 °F]	-40 ... +100 °C [-40 ... +212 °F]

Process connections

Standard	Thread size
EN 837	G ¼ B
	G ½ B
DIN EN ISO 1179-2 (formerly DIN 3852-E)	G ¼ A ¹⁾
	G ¼ female
ANSI/ASME B1.20.1	¼ NPT
	½ NPT
SAE J514 E	7/16-20 UNF with 74° taper
-	M20 x 1.5
-	G ½ male / G ¼ female
ISO 7	R ¼

1) Maximum overload safety 600 bar [8,700 psi]

Other process connections on request

Materials

Wetted parts

Measuring ranges ≤ 25 bar [≤ 400 psi]: 316Ti

Measuring ranges > 25 bar [> 400 psi]: 316Ti and S13800

Non-wetted parts

- Case: 316Ti
- Internal pressure transmission medium:
 - Measuring ranges ≤ 25 bar [≤ 400 psi]: synthetic oil
 - Measuring ranges > 25 bar [> 400 psi]: dry measuring cell
- Clamping nut: PA
- Angular connector: PA
- O-rings at the clamping nut: NBR
- Flat gasket: VMQ

Electrical connections

Electrical connection	Ingress protection	Wire cross-section	Cable diameter	Cable lengths
Angular connector DIN 175301-803 A	IP65	max. 1.5 mm ²	6 ... 8 mm	-
Angular connector DIN 175301-803 with ½ NPT	IP65	max. 1.5 mm ²	-	-
Circular connector M12 x 1 (4-pin)	IP67	-	-	-
Bayonet connector (6-pin)	IP67	-	-	-
½ NPT conduit male, with cable outlet	IP67	3 x 0.5 mm ²	6.8 mm	1.5 m, 3 m, 5 m, 10 m, 5 ft, 10 ft, 20 ft, 30 ft, others on request
Cable outlet				
■ Standard	IP67	3 x 0.5 mm ²	6.8 mm	1.5 m, 3 m, 5 m, 10 m, 5 ft, 10 ft, 20 ft, 30 ft, others on request
■ not adjustable	IP68 ¹⁾	3 x 0.5 mm ²	6.8 mm	
■ adjustable	IP68 ¹⁾	3 x 0.5 mm ²	6.8 mm	

1) 72 h / 300 mbar [4.4 psf]

Short-circuit resistance

S+ vs. U-

Reverse polarity protection

U+ vs. U-

Overvoltage protection

DC 36 V

Insulation voltage

DC 500 V

Connection diagrams

Angular connector DIN 175301-803 A			
		2-wire	3-wire
	U+	1	1
	U-	2	2
	S+	-	3

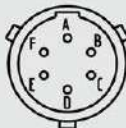
Bayonet connector (6-pin)			
		2-wire	3-wire
	U+	A	A
	U-	B	B
	S+	-	C









Angular connector DIN 175301-803 A with ½ NPT			
		2-wire	3-wire
	U+	1	1
	U-	2	2
	S+	-	3

½ NPT conduit male, with cable outlet			
		2-wire	3-wire
	U+	red (RD)	red (RD)
	U-	black (BK)	black (BK)
	S+	-	brown (BN)

Circular connector M12 x 1 (4-pin)			
		2-wire	3-wire
	U+	1	1
	U-	3	3
	S+	-	4

Cable outlets			
		2-wire	3-wire
	U+	brown (BN)	brown (BN)
	U-	green (GN)	green (GN)
	S+	-	white (WH)
	Shield	grey (GY)	grey (GY)

Approvals

Logo	Description	Country
	EU declaration of conformity <ul style="list-style-type: none"> ■ EMC directive EN 61326 emission (group 1, class B) and interference immunity (industrial application) ■ Pressure equipment directive ■ RoHS directive 	European Union
	CSA Safety (e.g. electr. safety, overpressure, ...)	Canada
	EAC EMC directive	Eurasian Economic Community
	GOST Metrology, measurement technology	Russia
	KazInMetr Metrology, measurement technology	Kazakhstan
-	MTSCHS Permission for commissioning	Kazakhstan
	BelGIM Metrology, measurement technology	Belarus
	UkrSEPRO Metrology, measurement technology	Ukraine
	Uzstandard Metrology, measurement technology	Uzbekistan
-	CRN Safety (e.g. electr. safety, overpressure, ...)	Canada

Manufacturer's information and certifications

Logo	Description
-	MTTF: > 100 years
-	China RoHS directive

Approvals and certificates, see website

Dimensions in mm

with angular connector DIN 175301-803 A

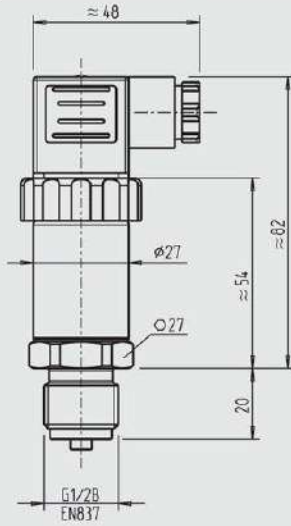

Weight: approx. 0.2 kg

with angular connector DIN 175301-803 with 1/2 NPT

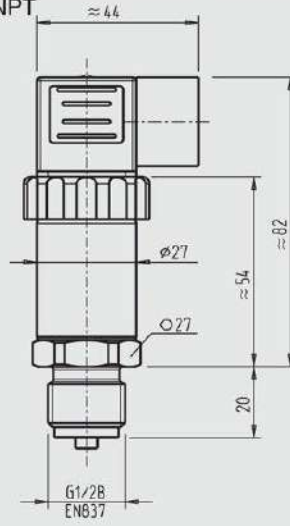

Weight: approx. 0.2 kg

with circular connector M12 x 1 (4-pin)

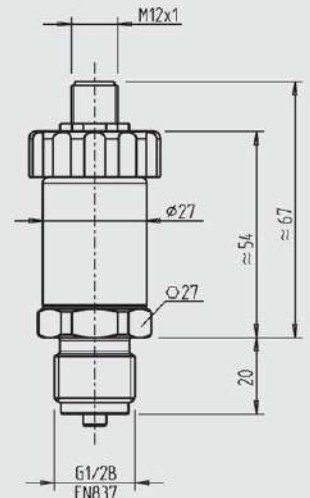

Weight: approx. 0.2 kg

with bayonet connector (6-pin)

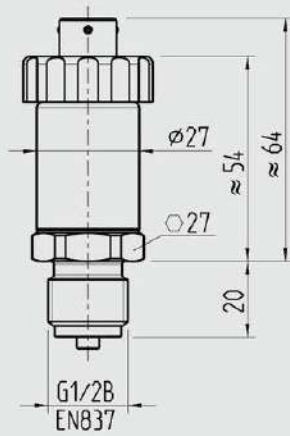

Weight: approx. 0.2 kg

with 1/2 NPT conduit male, with cable outlet

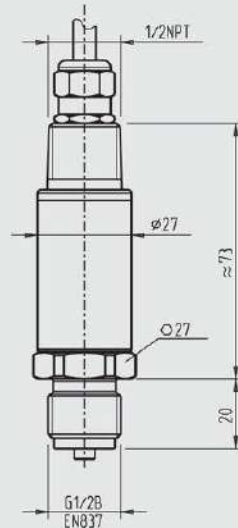

Weight: approx. 0.2 kg

with cable outlet, standard

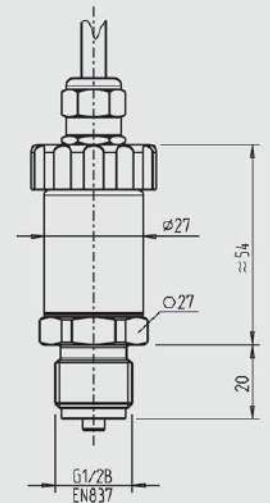

Weight: approx. 0.2 kg

with cable outlet, not adjustable

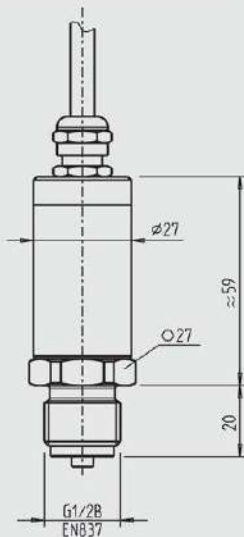

Weight: approx. 0.2 kg

with cable outlet, adjustable

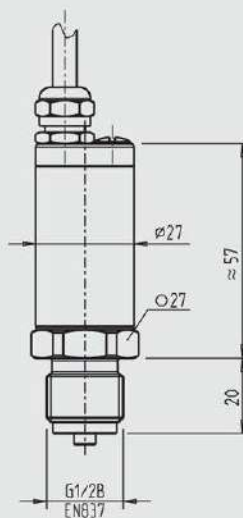

Weight: approx. 0.2 kg

Process connections

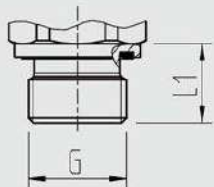

G	L1
G ¼ A	12

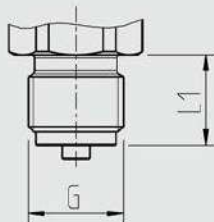

G	L1
G ¼ B	13
G ½ B	20
M20 x 1,5	20

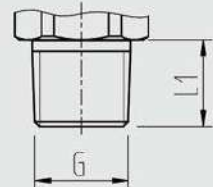

G	L1
¼ NPT	13
½ NPT	19
R ¼	13

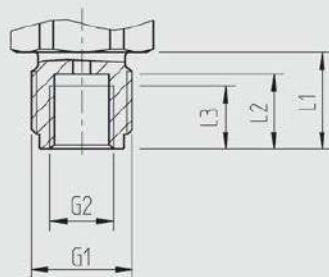

G1	G2	L1	L2	L3
G ½ B	G ¼	20	15,5	13

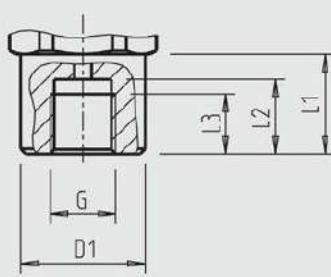

G	D1	L1	L2	L3
G ¼ female	25	20	15	12

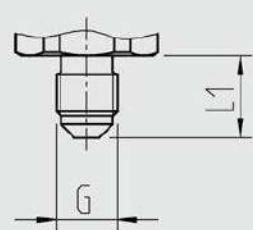

G	L1
7/16-20 UNF with 74° taper	15

For information on tapped holes and welding sockets, see Technical Information IN 00.14 at www.wika.com.

Accessories and spare parts

Mating connector

Description	Order number		
	without cable	with 2 m cable	with 5 m cable
Angular connector DIN 175301-803 A			
■ with cable gland, metric	11427567	11225793	11250186
■ with cable gland, conduit	11022485	-	-
Circular connector M12 x 1 (4-pin)			
■ straight	2421262	11250780	11250259
■ angled	2421270	11250798	11250232

Sealings for mating connectors

Mating connector	Order number
Angular connector DIN 175301-803 A	1576240

Sealings for process connection

Thread size	Order number			
	Copper	Stainless steel	NBR	FKM
G ¼ B EN 837	11250810	11250844	-	-
G ½ B EN 837	11250861	11251042	-	-
G ¼ A DIN 3852-E	-	-	1537857	1576534
M20 x 1.5	11250861	11251042	-	-